

Hilong Group of Companies

DRILLING TOOLS



www.hilonggroup.com



HILONG GROUP OF COMPANIES



Corporate Culture

Hilong Culture
Openness Inclusiveness Unity

Hilong Spirit
Passion Dedication Loyalty

Brief Introduction

of Hilong Drilling Tools Business



Drilling tools is one of the core businesses of Hilong Group. Hilong specializes in R&D, production, and sales of drilling tools, and its main products include drill pipe, Heavy Weight drill pipe, drill collar, and other drill string components. The products are applicable for all onshore and offshore drilling, Coal Bed Methane (CBM) and directional drilling.

Hilong Drilling Tools has established a sophisticated global marketing and service network, providing convenient and efficient services for clients across the world. Hilong has modernized and integrated drilling tools manufacturing bases in China and Russia, equipped with advanced production, inspection, and testing equipment, and a complete quality assurance system, ensuring clients experience the highest quality products and services.

Hilong has a professional R&D center that continuously develops high performance drilling tools to meet the requirements of harsh drilling environments, improve drilling efficiency, and ensure drilling safety.

Hilong is committed to building the world's leading oilfield equipment and service brand. It consistently adheres to the core development strategy of technological innovation and internationalization. With high-quality, high-tech and differentiated products and integrated services, Hilong consistently creates the highest value for global clients!



Openness

To be "open" is to promote a broad awareness
And utilize proactive actions that are at once up-to-date



Inclusiveness

Willingness to complement
Learning from others and adoption of a modern



Unity

Concepts and awareness of the big picture
Unity and mutual assistance within the team



Passion Dedication Loyalty

Have been infused into the blood of the Hilong people, enabling them to break through all difficulties



CONTENTS

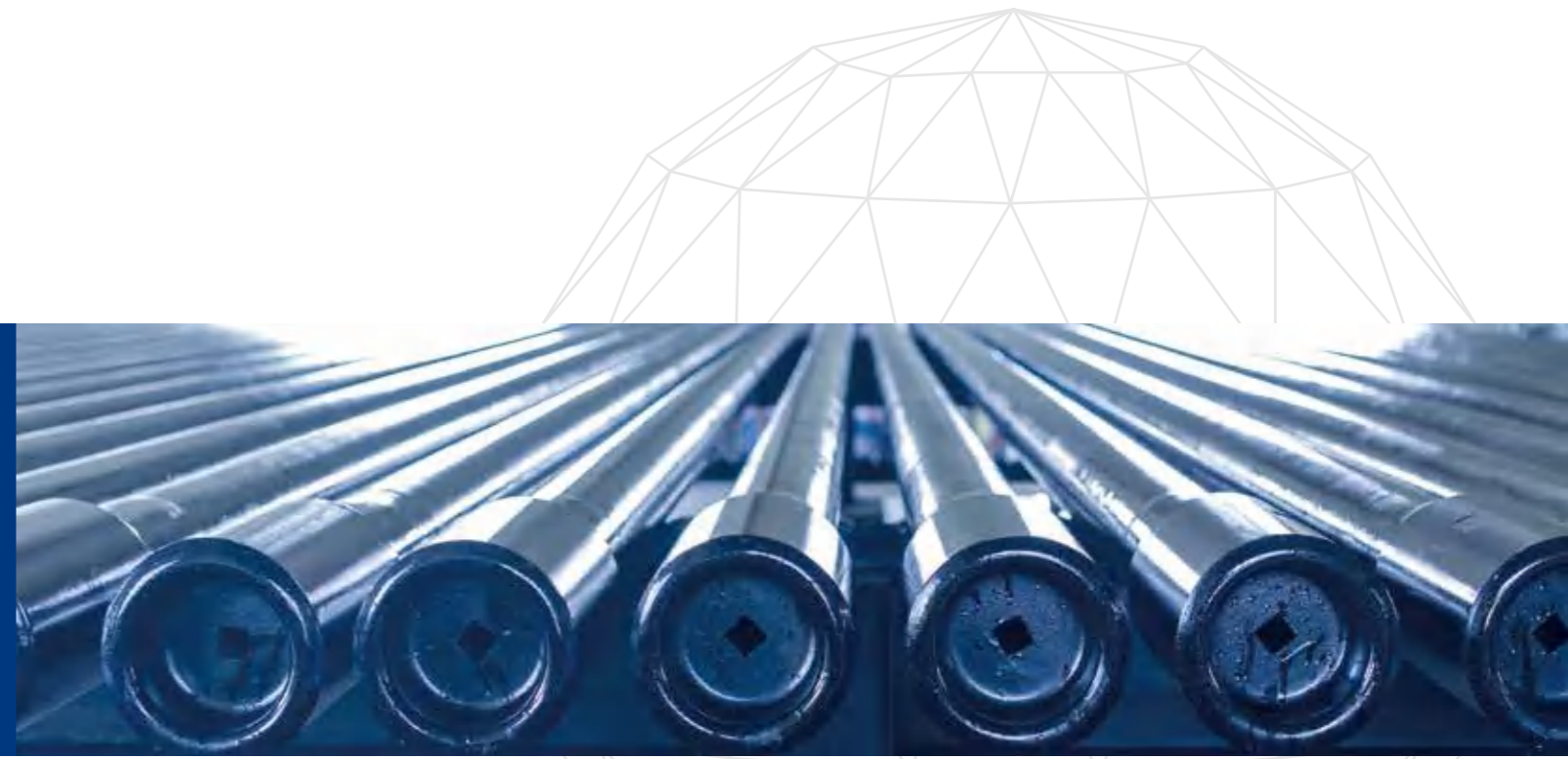

<p>04 Research and Development</p> <p>06 Quality</p> <p>07 HSE Policy, Goals and Commitment</p> <p>08 Drill Pipe</p> <p>12 Heavy Weight Drill Pipe (HWDP)</p> <p>14 Drill Collar</p>	<p>15 Hilong Premium Connection: HLIDS® & HLMT® Series</p> <p>16 Hilong Premium Connection: HLST® & HLIST® Series</p> <p>17 Hilong Premium Connection: HLNST® Series</p> <p>18 Hilong Premium Connection: HLDT-GS® Series</p> <p>19 Hilong Super High-Strength Drill Pipe</p> <p>20 Hilong Sour Service Drill Pipe / Sour Service Heavy Weight Drill Pipe</p> <p>24 Hilong Non-Slip-Crush Drill Pipe</p> <p>25 Hilong Slip-Protected Drill Pipe</p> <p>26 Hilong Flush Hole Drill Pipe</p> <p>27 Hilong Double-Walled Drill Pipe</p> <p>28 Hilong Arctic Service Drill Pipe</p> <p>29 Hilong Landing String Drill Pipe</p> <p>30 Hilong's Electronic Tag Drilling Tool and IoT Management System</p> <p>32 Hilong Efficient Cuttings Bed Clean Drill Tool: HLECDT™</p> <p>33 Hilong Large Size HDD (Horizontal Directional Drilling) Drill Pipe</p> <p>34 Hilong Slim Drill Pipe</p>	<p>Appendix A (Tables in SI units)</p> <p>35 Table A.1 Commonly-used Drill Pipes Data</p> <p>41 Table A.2 Commonly-used Sour Service Drill Pipes Data</p> <p>45 Table A.3 Commonly-used Heavy Weight Drill Pipes Data</p> <p>46 Table A.4 Commonly-used Drill Collars Data</p> <p>47 Table A.5 HLIDS® Connection Mechanical Characteristics</p> <p>48 Table A.6 HLMT® Connection Mechanical Characteristics</p> <p>49 Table A.7 HLST® Connection Mechanical Characteristics</p> <p>50 Table A.8 HLIST® Connection Mechanical Characteristics</p>	<p>Appendix B (Tables in USC units)</p> <p>51 Table B.1 Commonly-used Drill Pipes Data</p> <p>57 Table B.2 Commonly-used Sour Service Drill Pipes Data</p> <p>61 Table B.3 Commonly-used Heavy Weight Drill Pipes Data</p> <p>62 Table B.4 Commonly-used Drill Collars Data</p> <p>63 Table B.5 HLIDS® Connection Mechanical Characteristics</p> <p>64 Table B.6 HLMT® Connection Mechanical Characteristics</p> <p>65 Table B.7 HLST® Connection Mechanical Characteristics</p> <p>66 Table B.8 HLIST® Connection Mechanical Characteristics</p> <p>Appendix C</p> <p>67 Table C.1 Hilong Drilling Tools Request for Quotation Template</p>
---	--	---	---

Research and Development

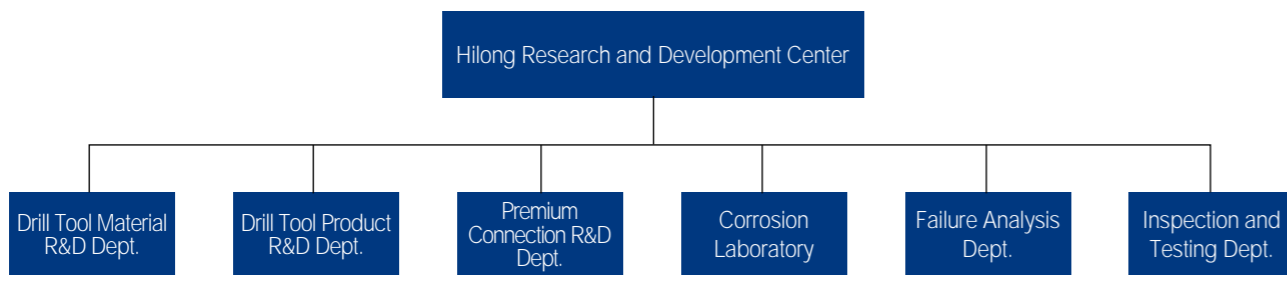

Hilong has a specific R&D center dedicated to research and technological innovation of drilling tools to continuously meet the needs of users and drilling operation. To drilling the wells deeper, longer and more effectively and safely is the focus and direction of our R&D.

The R&D Center is equipped with advanced anti-hydrogen sulfide stress corrosion testing equipment, scanning electron microscope, MTS tensile and twisted composite material dynamic testing system, and other internationally first class testing equipment, and was approved by the China National Accreditation Service for Conformity Assessment (CNAS).

- Hilong's proprietary connection (HLIDS®/HLMT®/HLST®/HLIST®/HLDT-GS® series) can significantly improve torsional strength and hydraulic performance, and is suitable for deep wells, extra deep wells, ERD, etc.
- Hilong's super high-strength drill pipe (HLDT-SH®Z140, HLDT-SH®V150, HLDT-SH®U165) with higher tensile and torsional strength, enables the drill pipe to be drilled deeper and farther, and is suitable for deep wells, extra deep wells, and ERD.
- Hilong's Sour Service drill pipe and Heavy weight drill pipe are suitable for oil and gas drilling in a hydrogen sulfide environment. The highest steel grade reaches 125KSI, which meets the drilling requirements of deep wells containing hydrogen sulfide, extra deep wells, and ERD.
- Using special toothless pneumatic slips, Hilong's Non-Slip-Crush drill pipe can completely protect the drill pipe body from slip tooth bites and extend drill pipe life. It can significantly improve the speed and efficiency of TIH and TOH (efficiency increased by more than 15%), reducing non-drilling time, lowering the cost of operation.
- Hilong's slip-protected drill pipe has a thick-walled slip-protected section at the box end of drill pipe, which improves the anti-crushing ability of the drill pipe, reduces the risk of "washouts" at the slip, and increases the fatigue life of the drill pipe.
- Hilong's landing string drill pipe is suitable for landing heavy casing strings in extra-deep wells and offshore drilling wells. It has a large-size outer diameter, uses extra-high strength materials, and has a special slip-protected section and sufficient tensile hoisting capacity.

- With an integrated IoT management system and intelligent reader/writer devices, Hilong's Electronic Tag Drilling Tool and IoT Management System efficiently and accurately achieves full life cycle management of drilling tools from production, warehouse in/out, allocation, use, maintenance, and inspection, to scrapping.
- Hilong's efficient cuttings bed clean drill tool reduces cutting deposits, improves drilling speed and saves drilling time. It is especially suitable for wells with large inclination and ERD.
- Hilong's slim drill pipe is specially used for small hole drilling, workover, and window sidetracking drilling and short radius horizontal well drilling.

With industry development and technological innovation, there is an essential need in the industry for a drilling tool solution that performs better than standard API drilling tools, to meet the needs of deeper wells and more complex well conditions, while being more efficient and economical.

Our goal is to provide users with the most optimized products and services.

You are welcome to contact Hilong to learn more about our professional oil drilling tool solution.



Torsional Strength Comparison with Tool Joint OD 7", ID 4", SMYS 120ksi

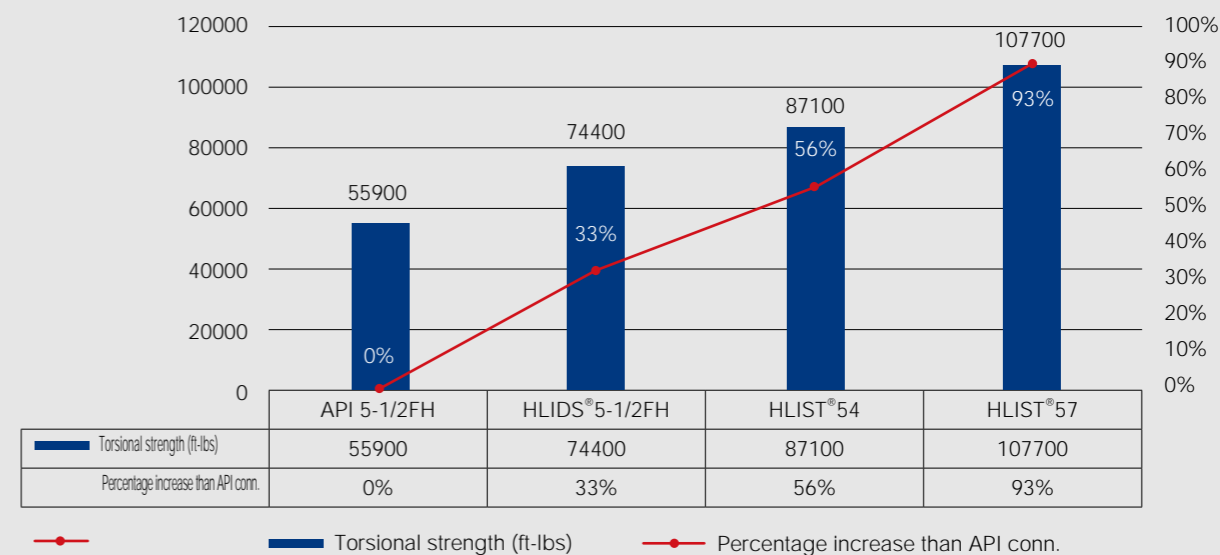

Quality

Hilong has always adhered to the concept of systematic management. We have established a complete quality assurance system for our production activities, have passed the ISO 9001 and API SPEC Q1 quality management system certifications, and have obtained the API Monogram Program licenses of API SPEC 5DP and API SPEC 7-1 as well as the NS-1 certification.

Hilong implements quality management control in every link of the production process starting from raw material procurement. We have fulfilled comprehensive measures in terms of personnel, equipment, materials, production process, operation standards, production environment, and incentive mechanisms, to ensure product quality. The adoption of the MES and ERP systems realizes real-time monitoring of the entire production process. Every product, every production link, and every quality control point has relevant quality control, ensuring the quality of the delivered products meets the specified requirements.



HSE Policy, Goals and Commitment

HSE policy:

People-oriented, full participation, scientific management, and sustainable development.

HSE goals:

Pursue zero accidents, zero injuries, zero pollution, and create first-class HSE performance.

HSE commitments:

Abiding by the laws and regulations of the country and region where we are located, respect local customs and habits, and respond to customer HSE requirements.

Pursue the goal of not harming people and the environment, protect the environment, save energy, promote clean production, and commit to sustainable development.

Drill Pipe

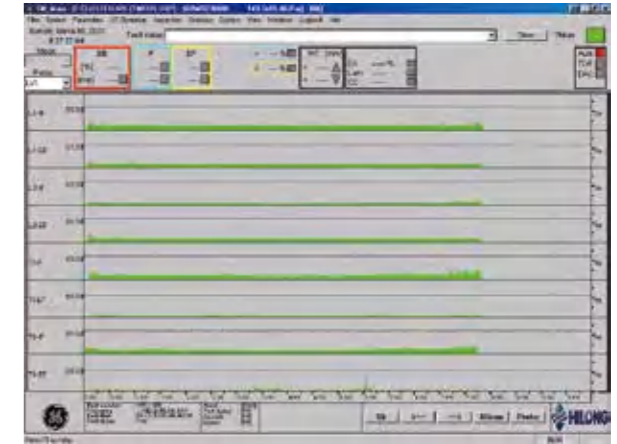

Drill Pipe Body Full Length Automatic Ultrasonic Test (FLUT)

Modern drilling requires more efficient activities (faster drilling speed, higher drilling quality, suitability for special drilling environments, and safer drilling). As the main drilling tool, the performance and quality of the drill pipe are pivotal to drilling ability, efficiency, quality, and drilling safety.

Hilong is committed to the technological innovation of drill pipes. It constantly designs and develops high-end drill pipe products to meet the requirements of modern efficient drilling, and with exceptional quality and excellent product performance, it contributes to meeting the needs from clients and modern drilling projects.

Hilong Drill Pipe Quality and Performance

- Excellent steel purity, metallurgical quality, microstructure uniformity, impact toughness and fatigue resistance.
- Adopt optimized Miu and Miu-R designs, combined with a special stable upsetting process, which improves the fatigue resistance on upsetting end of the drill pipe.
- Using MES and ERP systems, it can realize comprehensive information management of the entire process from order-to-shipment, including the entire manufacturing process, inspection and test acceptance, and product traceability.



Pipe-body Heat Treatment



Upset Profile and MIU Control

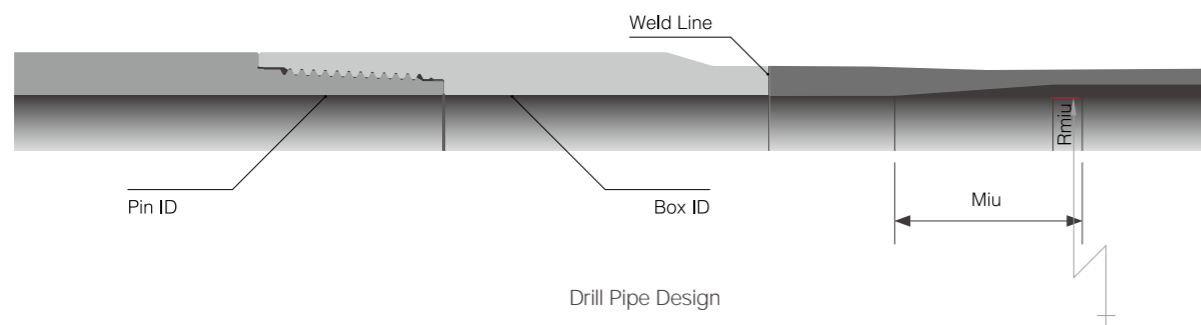

Drill Pipe Design

- Pipe body 100% FLUT (longitudinal, transverse, oblique ultrasonic testing + ultrasonic thickness measurement) + 100% pipe end MPI (or UT), drill pipe tool joint 100%UT+100%MPI, welding zone 100%UT+100% MPI.
- Integration: drill pipe tool joint manufacturing, upsetting, heat treatment and friction welding, hardbanding wire production and application, internal coating material production and application.

Drill Pipe Product Range

Main drill pipe specifications (outer diameter):

2 3/8", 2 7/8", 3 1/2", 4", 4 1/2", 5", 5 1/2", 5 7/8", 6 5/8", 7 5/8", 8 5/8"

Please refer to Table A.1 or Table B.1 for a list of recommended sizes of Hilong's commonly used drill pipes.

Drill pipe product standards:

Adopt optimized Miu and Miu-R designs, combined with a special stable upsetting process, which improves the fatigue resistance on upsetting end of the drill pipe.

Drill pipe product type:

- Standard drill pipe (API Spec 5DP/NS-1/DS-1 standard drill pipe)
 - Hilong proprietary drill pipe
1. Hilong premium connection drill pipe
 2. Hilong super high-strength drill pipe
 3. Hilong sour service drill pipe and heavy weight drill pipe
 4. Hilong non-slip-crush drill pipe
 5. Hilong slip-protected drill pipe
 6. Hilong flush hole drill pipe
 7. Hilong double-walled drill pipe
 8. Hilong arctic service drill pipe
 9. Hilong landing string drill pipe
 10. Hilong electronic tag drilling tool and IoT management system
 11. Hilong efficient cuttings bed clean drill tool: HLECDT™
 12. Hilong Large Size HDD (Horizontal Directional Drilling) Drill Pipe
 13. Hilong slim drill pipe



Drill Pipe

Hilong's Drill Pipe Premium Connection

Advantages of Hilong Premium Connection:

- Improves the torsional strength and torque capacity of tool joint, due to which it is more suitable for HDD wells and extra deep wells.
- Increases the inside diameter of tool joint, thereby improving hydraulic performance and drilling efficiency. It is especially suitable for HDD wells and extra deep wells.
- Reduces the external diameter of tool joint, is more suitable for small hole drilling and improves the fishing ability.
- Improves the stress distribution, reduces the stress concentration factor, and improves the fatigue resistance of tool joint.

Table 1. Nominal Drill Pipes and Hilong Proprietary Connections

Nominal Size Hilong Proprietary Connection	2 3/8"	2 7/8"	3 1/2"	4"	4 1/2"	5"	5 1/2"	5 7/8"	6 5/8"
HLIDS®	HLIDS®23 HLIDS®26	HLIDS®26 HLIDS®31	HLIDS®31 HLIDS®38	HLIDS®38 HLIDS®40	HLIDS®40 HLIDS®46	HLIDS®50	HLIDS®5-1/2FH	HLIDS®5-1/2FH	HLIDS®6-5/8FH
HLMT®	HLMT®2-3/8PAC	HLMT®2-7/8PAC	HLMT®38	HLMT®38 HLMT®40	HLMT®46	HLMT®50	HLMT®5-1/2FH		
HLST®	HLST®26	HLST®26 HLST®31	HLST®31 HLST®36 HLST®39	HLST®31 HLST®36 HLST®39	HLST®40 HLST®46	HLST®46 HLST®52	HLST®52 HLST®54 HLST®57	HLST®57	
HLIST®			HLIST®38 HLIST®39	HLIST®38 HLIST®39	HLIST®46	HLIST®46 HLIST®50	HLIST®54 HLIST®57	HLIST®57	

Hilong Special Drill Pipe Material / Steel Grade

Hilong sour service drill pipe grade

Usage: applicable for sulfur-containing and high-sulfur drilling environment.

Steel grade: HLDT-SS®75, HLDT-SS®95, HLDT-SS®105, HLDT-SS®110, HLDT-S®120, HLDT-S®125.

Please refer to Table A.2 or Table B.2 for a list of recommended sizes of Hilong's anti-sulfur drill pipe.

Hilong super high-strength drill pipe

Usage: Suitable for deep wells, extra deep wells, and extended reach wells, with high strength, high toughness, and high fatigue resistance

Steel grade: HLDT-SH®Z140, HLDT-SH®V150, HLDT-SH®U165

Hilong arctic service drill pipe

Usage: Low-temperature environment

Steel grades: HLDT-AS®75, HLDT-AS®95, HLDT-AS®105, HLDT-AS®135

Drill Pipe Manufacturing Flow Chart

Tool Joint Manufacturing Flow Chart

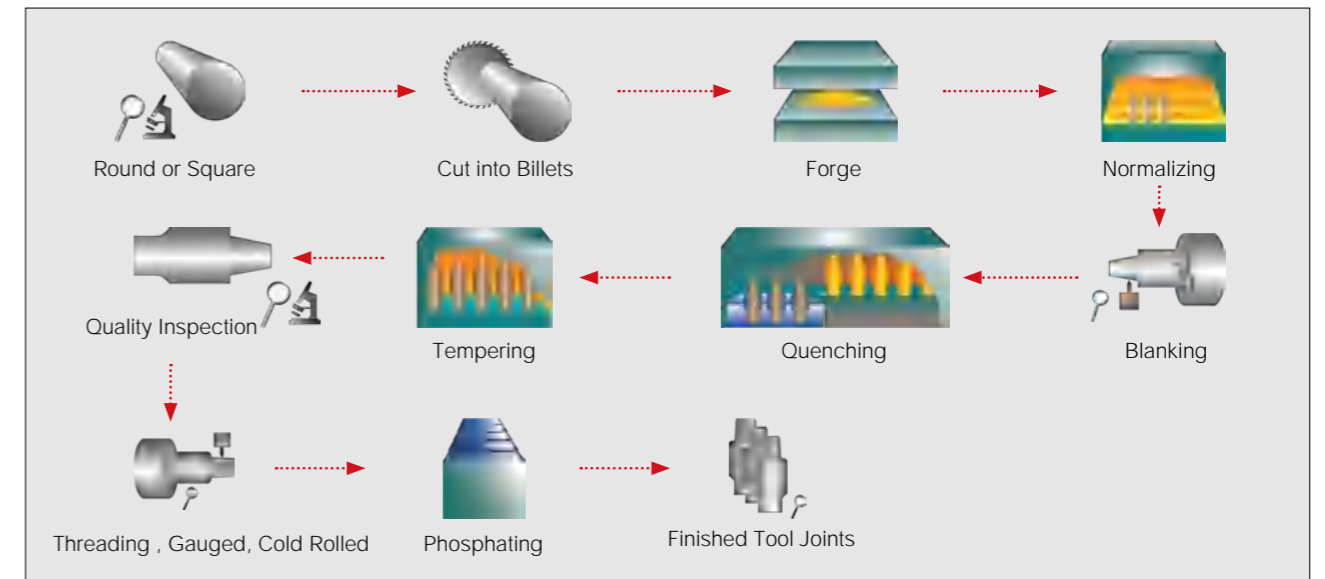

Drill Pipe Body Manufacturing Flow Chart

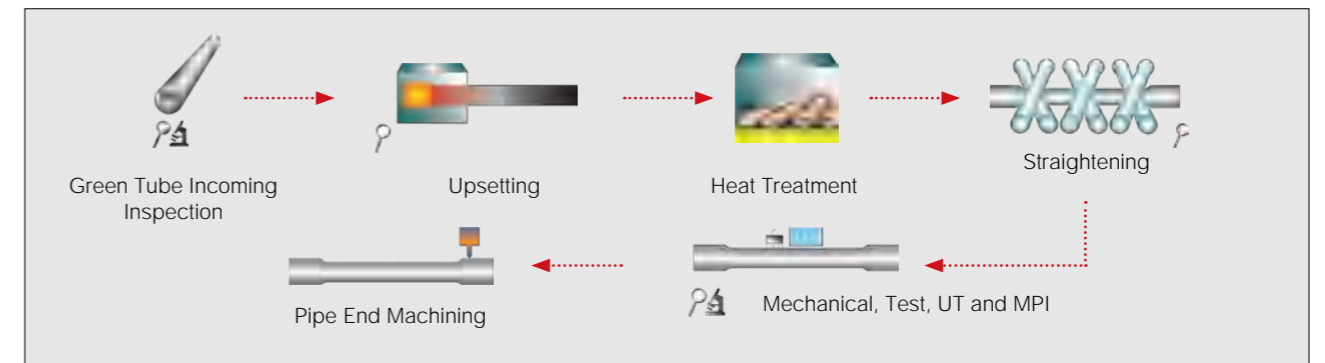

Drill Pipe Welding Flow Chart

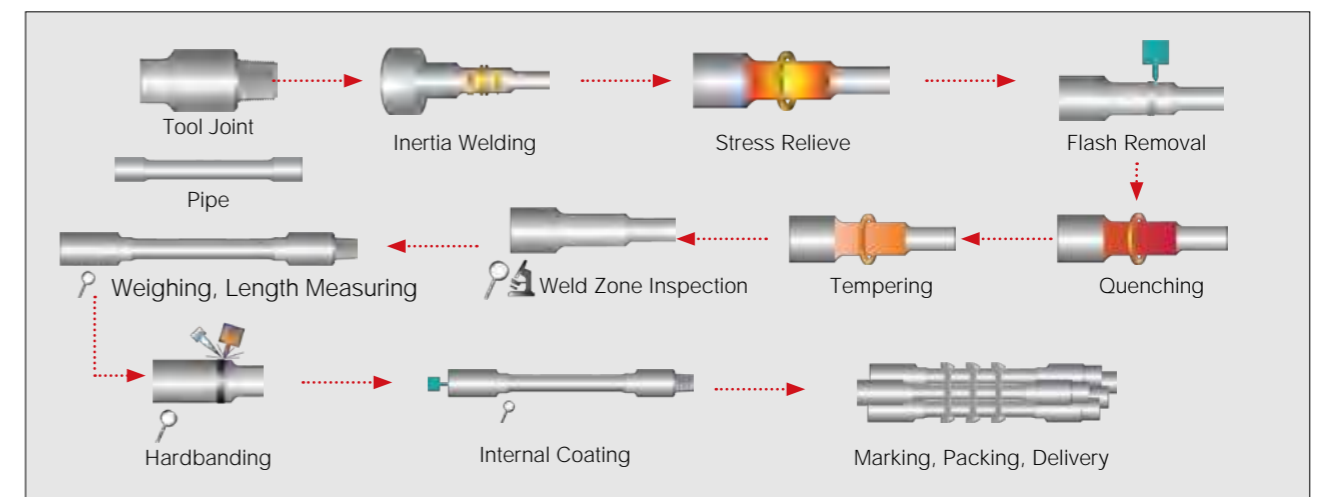

Heavy Weight Drill Pipe (HWDP)

In the drilling process, HWDP is a transition from a flexible drill pipe to a rigid drill collar. Moreover, it replaces drill collar to reduce friction in horizontal and extended reach wells.

- Reduces the stress concentration between the drill pipe and drill collar.
 - Prevents sticking of drilling tool due to differential pressure.
 - Reduces friction and torque.
 - Mitigates the problem of excessive flexion on center wear pad
- Hilong Drilling Tools is committed to the quality and technological innovation of HWDP. It continues to develop HWDP that meet special environments and drilling conditions.

Hilong HWDP Quality and Performance

- The integral HWDP and welded HWDP are manufactured by quenching and tempering heat treatment process, which ensures that the HWDP body has better impact toughness.
- Using MES and ERP systems, it can realize comprehensive information management of the entire process from order-to-shipment, including the entire manufacturing process, inspection and test acceptance, and product traceability.
- Pipe body 100% FLUT (longitudinal, transverse, ultrasonic thickness measurement) + Upset end 100% UT or 100% MPI, HWDP tool joints and welding zone 100% UT + 100% MPI.
- Options for improving the performance of HWDP: Increased length of tong space for HWDP tool joint, make and break, cold rolling of threads, spiral grooves on center wear pad, internal coating, and hardbanding.

HWDP Product Type

- Integral HWDP and welded HWDP.
- Welded HWDP includes standard strength HWDP, high strength HWDP, sour services HWDP, and Hilong premium connection HWDP.
- Without spiral groove and with spiral groove.

HWDP Specification (OD)

2 7/8", 3 1/2", 4", 4 1/2", 5", 5 1/2", 5 7/8", 6 5/8".

Please refer to Table A.3 or Table 3 for the specifications of commonly used heavy weight drill pipe.

HWDP Product Standard

API Spec 7-1, NS-1, DS-1, Hilong high-strength welded HWDP specification, Hilong sour service HWDP specification.



Table 2. API Integral HWDP Mechanical Properties

HWDP					
Tool Joint OD Range	Min. Yield Strength	Min. Tensile Strength	Min. Elongation (%)	Toughness LCVN, Full Size, 21°C Min. Avg. / Min. Single	Min. Hardness (BHN)
≤ 6.875"	110 ksi	140 ksi	13	40 / 35 ft-lbf	285
≤174.6 mm	758 Mpa	965 Mpa		54 / 47J	
> 6.875"	100 ksi	135 ksi	13	40 / 35 ft-lbf	285
> 174.6 mm	689 Mpa	931 Mpa		54 / 47J	

Table 3. API Welded HWDP Mechanical Properties

Tool Joint						Pipe Body		
Tool Joint OD Range	Min. Yield Strength	Min. Tensile Strength	Min. Elongation (%)	Toughness LCVN, Full Size, 21°C Min. Avg. / Min. Single	Min. Hardness (HBW)	Min. Yield Strength	Min. Tensile Strength	Min. Elongation (%)
≤ 6.875"	110 ksi	140 ksi	13	40 / 35 ft-lbf	285	55 ksi	95 ksi	18
≤174.6 mm	758 Mpa	965 Mpa		54 / 47J		379 Mpa	655 Mpa	
> 6.875"	100 ksi	135 ksi	13	40 / 35 ft-lbf	285	55 ksi	95 ksi	18
> 174.6 mm	689 Mpa	931 Mpa		54 / 47J		379 Mpa	655 Mpa	

Table 4. Hilong High Strength Welded HWDP Mechanical Properties

Grade	Pipe Body			Tool Joint			
	Min. Yield Strength	Min. Tensile Strength	Toughness LCVN, Full Size, 21°C Min. Avg. / Min. Single	Min. Yield Strength	Min. Tensile Strength	Hardness (BHN)	Toughness LCVN, Full Size, 21°C Min. Avg. / Min. Single
HL-HW75	75 ksi	95 ksi	31 / 24 ft-lbf	120 ksi	140 ksi	285-341	40 / 35 ft-lbf
	517 Mpa	655 Mpa	42 / 32 J	827 Mpa	965 Mpa		54 / 47J
HL-HW90	90 ksi	105 ksi	31 / 24 ft-lbf	120 ksi	140 ksi	285-341	40 / 35 ft-lbf
	621 Mpa	724 Mpa	42 / 32 J	827 Mpa	965 Mpa		54 / 47J
HL-HW110	110 ksi	125 ksi	31 / 24 ft-lbf	120 ksi	140 ksi	285-341	40 / 35 ft-lbf
	758 Mpa	862 Mpa	42 / 32 J	827 Mpa	965 Mpa		54 / 47J

Note: Tool joint SMYS at 130ksi is Optional.

Table 5. Hilong Sour Service HWDP Mechanical Properties

Grade	Pipe Body					Tool Joint				
	Min. Yield Strength	Min. Tensile Strength	Toughness LCVN, Full Size, 21°C Min. Single	max Hardness (HRC)	SSC Test (NACE TM0177)	Min. Yield Strength	Min. Tensile Strength	Toughness LCVN, Full Size, 21°C Min. Single	Hardness max Avg., max Single (HRC)	SSC Test (NACE TM0177)
HLHW-SS [®] 75	75 ksi	90 ksi	55 ft-lbf	24	Method A, Solution A, 85% SMYS	110 ksi	125 ksi	66 ft-lbf 90J	30, 32	Method A, Solution A, 65% SMYS
	517 Mpa	621 Mpa	75J			758 Mpa	862 Mpa			
HLHW-SS [®] 90	90 ksi	100 ksi	55 ft-lbf	27	Method A, Solution A, 85% SMYS	110 ksi	125 ksi	66 ft-lbf 90J	30, 32	Method A, Solution A, 65% SMYS
	621 Mpa	689 Mpa	75J			758 Mpa	862 Mpa			

Hilong Premium Connection:

HLIDS[®] & HLMT[®] Series

Product Introduction

HLIDS[®] is an API compatible high torque double shoulder connection developed by Hilong.

HLMT[®] is a double shoulder connection designed and developed refer to API connection and customer's requirement on site.

HLIDS[®] and HLMT[®] have features as follows:

- The same standard thread profile as API;
- Double shouldered design;
- Smooth transmission on inside diameter;

Drill Collar

The drill collar is a thick-walled drilling tool that applies bit pressure, to enhance drilling.

Hilong API drill collar specification includes:

- Size (OD): 3-1/8" to 11".
- Type: Slick drill collar, spiral drill collar, non-magnetic drill collar.
- Drill collar specification: API Spec 7-1, API Spec 7-2, API RP 7G, NS-1, DS-1.
- Other proprietary products of Hilong that applicable to deep well and harsh environment drilling.

Please refer to Table A.4 or Table B.4 for the specifications of commonly used API drill collars.

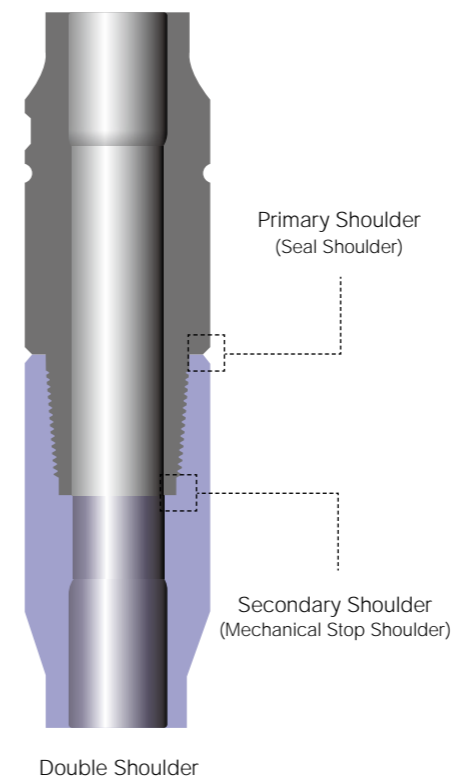

Product Advantage

- Higher Torque: by using HLIDS[®] and HLMT[®] connections with current API ODs and IDs will result in 20%~50% of torque capacity higher than API.
- While maintaining required torsional strength, it can:
 - minimize the tool joint OD;
 - maximize the ID;
- High fatigue resistance, thus prolong the pipe service life
- Improving hydraulic efficiency and reduce washout.

Product Specification

HLIDS[®] series includes HLIDS[®]23, HLIDS[®]26, HLIDS[®]31, HLIDS[®]38, HLIDS[®]40, HLIDS[®]46, HLIDS[®]50, HLIDS[®]5 1/2FH and HLIDS[®]6 5/8FH etc. and can be applied to all API drill pipes with standard steel grades and specifications from 2 3/8 to 6 5/8 inches.

HLIDS[®] connection performance, Please see Table A.5 or Table B.5.

HLMT[®] series includes HLMT[®]2-3/8PAC, HLMT[®]2-7/8PAC, HLMT[®]38, HLMT[®]40, HLMT[®]46, HLMT[®]50 and HLMT[®]5-1/2FH etc.

HLMT[®] connection performance, Please see Table A.6 or Table B.6.

HLIDS[®] and HLMT[®] applicable well condition

Suitable for drilling under harsh conditions such as deep well, horizontal well, extended reach well and sulfur-containing environments.

Hilong Premium Connection:

HLST® & HLIST® Series

Product Introduction

HLST® & HLIST® are new generation super high torque double shoulder connection developed based on the structure of HLIDS®.

HLST® & HLIST® are more suitable used in deep well drilling, ERD, HDD, sour service and critical well etc.

Comparing with API connection, HLST® & HLIST® have the features as follows:

- Improved double shoulder structure
- Improved thread root radius designation
- Optimized thread pitch and taper

Product Advantage

- Super High Torsional Strength: 70% extra torsional strength over API connection;
- Increased anti-fatigue performance;
- While maintaining required torsional strength, it can:
 - minimize the tool joint OD;
 - maximize the ID;
- Reduced the internal erosion and improved hydraulic efficiency.

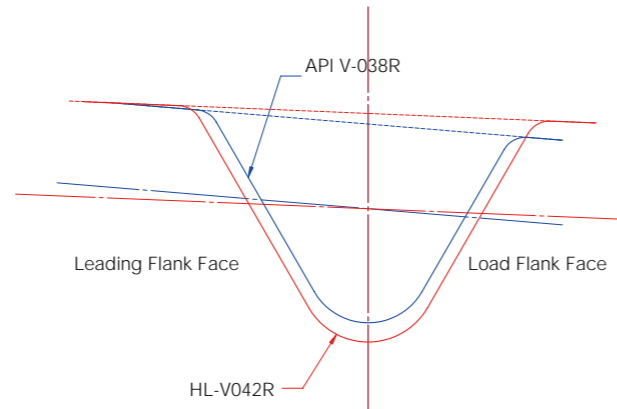

Product Specification

HLST® series including HLST®24, HLST®26, HLST®31, HLST®36, HLST®39, HLST®40, HLST®46, HLST®52, HLST®54, HLST®57, HLST®66 and etc.

HLST® connection performance, please see table A.7 or table B.7.

HLIST® series including HLIST®38, HLIST®39, HLIST®46, HLIST®50, HLIST®54, HLIST®57 and etc.

HLIST® connection performance, please see table A.8 or table B.8.

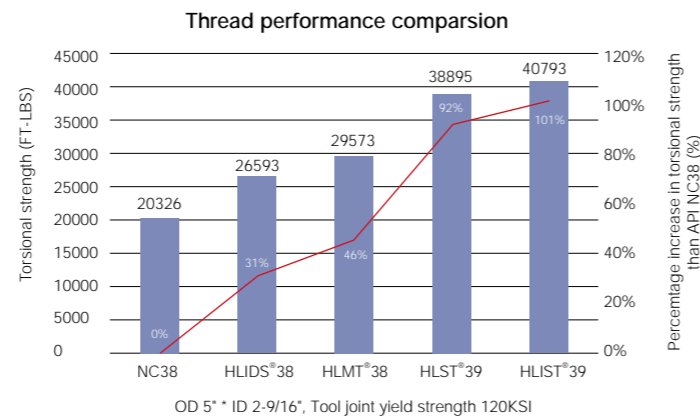

Hilong Premium Connection:

HLNST® Series

Product Introduction

Super high torque connection (HLNST®) series is a new generation double shoulder tool joint developed based on HLST® and HLIST®. It is more suitable for field use and convenient for maintenance.

Product Advantage

Performance

- High torsional strength. Under the same conditions, the torsional strength of HLST® and HLIST® can be reached or exceeded. This allows for use of streamlined tool joints and improved hydraulic performance.
- Better Fatigue Resistance. We have further improved the fatigue resistance of our products. HLNST® provides better fatigue resistance than HLST® or HLIST® connections, which can result in an increased product life.

Ease of Use

- Faster Makeup and breakout. HLNST® has significantly fewer turns from stab to makeup and breakout than comparable HLST® or HLIST® connections. This saves time and reduces the amount of wear on threads.
- Easier to Makeup. The improved guide side angle makes it easier to makeup. Reduce the difficulty of use.

Easier maintenance

- Improved tooth profile makes maintenance easier. Reduce maintenance costs.
- Reduced Repair Frequency. Repairs are expensive and time consuming. The field inspection tolerances for HLNST® have been widened without compromising performance, so you do not have to send the pipe in for repairs as often. This reduces downtime and saves you money.
- Less Recut Loss. There is less material loss on recuts, which allows for more recuts before needing to replace the string. The tong gripping distance has also been reduced, allowing more room for recut without adversely impacting performance.



Table 6. Common HLNST® Drill Pipe Configurations

Drill Pipe Size (in)	Nominal Weight	Grade	RSC Size	Recommended Dimension		Recommended MUT (ft-lbs)
				OD (in)	ID (in)	
3 1/2	13.30	S	HLNST® 38	4 3/4	2 9/16	20400
4	14.00	S	HLNST® 39	4 7/8	2 11/16	21700
4 1/2	16.60	S	HLNST® 43	5 1/4	3	26600
4 1/2	20.00	S	HLNST® 46	5 1/2	3	31700
5	19.50	S	HLNST® 51	6 3/8	3 1/2	51500
5	19.50	S	HLNST® 53	6 1/2	3 3/4	52000
5 1/2	21.90	S	HLNST® 54	6 5/8	4	52100
5 7/8	23.40	S	HLNST® 57	7	4 1/4	60400
6 5/8	27.70	S	HLNST® 66	8	5	89900

Recommended MUT value is calculated based on SMYS 130ksi and with a friction factor of 1.0 for compound. For more configuration information, please contact Marketing Department of HILONG.

Hilong Premium Connection:

HLDT-GS® Series

Product Introduction

HLDT-GS® can be used in Drill Stem Testing (DST) operation, hydraulic fracturing, well completion and underbalanced drilling with high metal-to-metal internal seal performance under gas pressure loading. Compared with the traditional single function drill string, using HLDT-GS® drill string can save time and reduce cost.

Product Advantage

Compared to API connections, HLDT-GS® has the following features:

- The use of double shouldered compound sealing structure allows the smooth transition of inner diameter, and smooth metal surface elastic interference fit achieves metal-to-metal seal.
- Seal integrity is not affected by tensile load and multiple drilling trips.

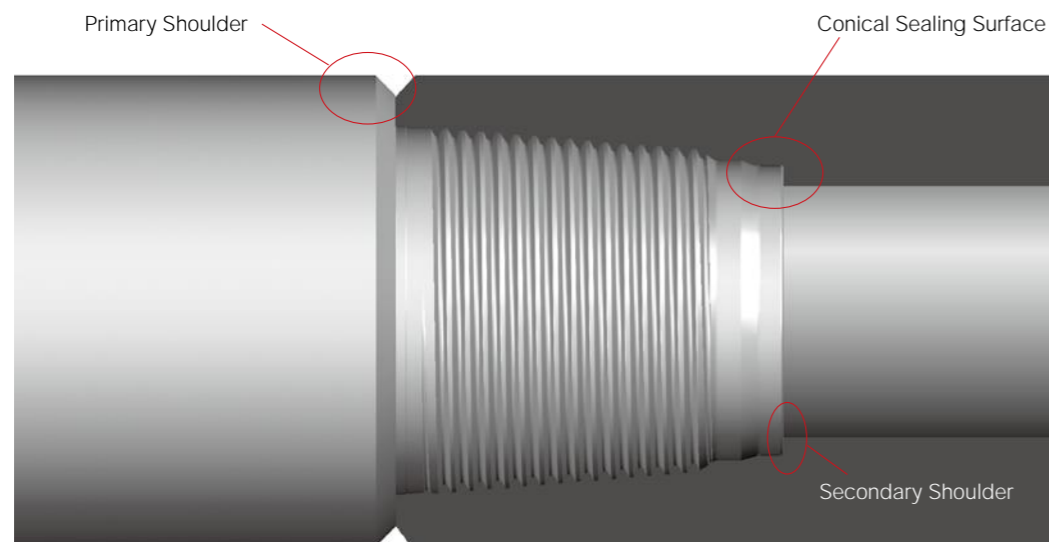

Product Specification

HLDT-GS®26, HLDT-GS®31, HLDT-GS®38, HLDT-GS®40, HLDT-GS®46, HLDT-GS®50, HLDT-GS®55 and HLDT-GS®65, the sealing structure can be applied to API Spec 7-2 and non-API rotary shouldered connections.

Product Performance

Good sealing performance, gas sealing capacity up to 15000 PSI (105MPa).

Hilong Super High-Strength Drill Pipe

Product Introduction

Hilong super high-strength steel grades HLDT-SH®Z140, HLDT-SH®V150 and HLDT-SH®U165 are proprietary products which designed specifically for deep and ultra-deep wells, extended reach drilling (ERD) wells, deep offshore and other critical drilling applications. With a special chemistry composition and carefully designed heat treatment process, HLDT-SH®Z140, HLDT-SH®V150 and HLDT-SH®U165 grades have realized high strength, high toughness and improved fatigue resistance.

Product Advantage

- Hilong proprietary high-strength grades provide superior tensile and torsional strength compared to API grades; thus be able to use for drilling deeper and further.
- The special material and unique heat treatment process facilitate to meet both yield strength and toughness requirements, it also has better fracture toughness and fatigue resistance;
- The thin-walled, light-weight and improved size design are conducive to improving the hydraulic efficiency of drilling, and is suitable for extended reach well and super-deep well.

Product Specification

Size Range: Including all API size from 2 3/8" to 6 5/8" inches.

Steel Grade: HLDT-SH®Z140, HLDT-SH®V150 and HLDT-SH®U165.

Table 7. Hilong Super High-Strength Drill Pipe Performance Data

Grade		HLDT-SH®Z140	HLDT-SH®V150	HLDT-SH®U165
Pipe Body	Yield Strength	140 ~ 160 ksi	150 ~ 165 ksi	≥165 ksi
		965 ~ 1103 Mpa	1034 ~ 1138 Mpa	≥1138 Mpa
	Tensile Strength	≥150 ksi	≥160 ksi	≥175 ksi
		≥1034 Mpa	≥1103 Mpa	≥1205 Mpa
Toughness LCVN, 3/4 Size, -21°C	≥50 ft-lbf ≥68J	≥40 ft-lbf ≥54J	≥40 ft-lbf ≥54J	
Tool Joint	Yield Strength	120 ~ 165 ksi	130 ~ 165 ksi	≥140 ksi
		827 ~ 1138 Mpa	896 ~ 1138 Mpa	≥965 Mpa
	Tensile Strength	≥140 ksi	≥145 ksi	≥150 ksi
		≥965 Mpa	≥1000 Mpa	≥1034 Mpa
Toughness LCVN, Full Size, -21°C	≥52 ft-lbf ≥70J	≥52 ft-lbf ≥70J	≥52 ft-lbf ≥70J	

Hilong Sour Service Drill Pipe / Sour Service Heavy Weight Drill Pipe



Brief Introduction

Drilling at H₂S environment with standard drill pipe is highly suspected to Sulfide Stress Cracking (SSC). Considering the sulfide stress cracking is extremely harmful, the developing of sour service drill pipe to meet the requirements of safe drilling in sulfur-containing environments is indeed necessary.

Sulfide stress cracking directly related tensional stress load, drilling environment (H₂S partial pressure, PH value and the temperture, ect.), also related to drill pipe materail SSC property. Through the development of drill pipe materials and manufacturing technology, it facilitate the drill pipe itself resistance to the sulfide stress cracking, and meeting the drilling requirements under the different sulfur-containing well is the direction and focus of Hilong's research and development over the years.

Key factors of sulfide stress cracking (SSC) property in Drill Pipe:

- Hardness
- Alloy designation of drill pipe material
- Metallurgy quality and purity
- Heat treatment quality (martensite transformation rate, uniformation of metallograhic structure, uniformity of hardness)

Key Factors to Sulfide Stress Cracking (SSC)

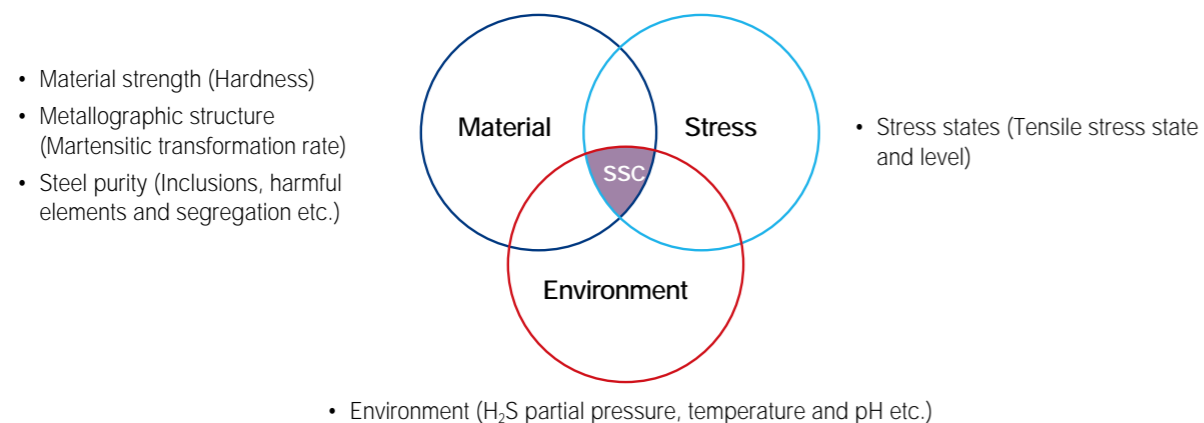

Hilong has developed a series of sour services drill pipes through drill pipe material designation and heat treatment technology research to meet with different H₂S enviornments and different drilling technology. The HLDT-S[®]120 and HLDT-S[®]125 developed in recent years are the high strength anti-hydrogen sulfide stress cracking drill pipe, satisfied the requirements of deep well drilling while taking into account of environmental hydrogen sulfide conditions, as a consequence it has created a condition for the development of deep wells containing hydrogen sulfide.

Product Advantage

- HLDT-SS[®]75, HLDT-SS[®]95, HLDT-SS[®]105, HLDT-SS[®]110 series of sour service drill pipes are the second generation of Hilong's SSC resistant drill pipe developed from HLDT-MS75, HLDT-MS95, HLDT-MS105/ HLDT-S[®]75, HLDT-S[®]95 and HLDT-S[®]105, meets the requirements of IRP1.8 and NACE test TM0177 method A & solution A, and can be used in critical sour drilling;
- HLDT-S[®]120 and HLDT-S[®]125 high-strength sour service drill pipes, satisfying the high strength and the resistance to hydrogen sulfide simultaneously, can be used for deep wells and extended reach wells in sour service environment.

SSC Severity Domains

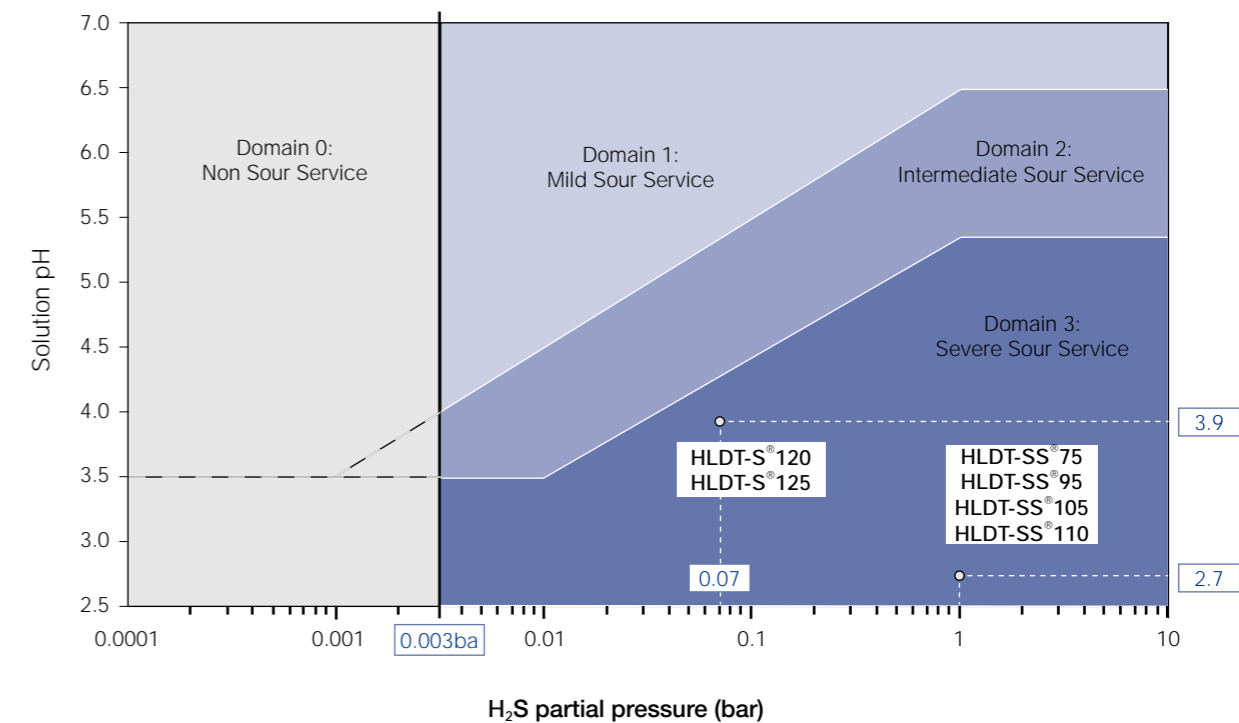

■ Product Size/Grade

Hilong Sour Service Drill Pipe Size:

2 3/8", 2 7/8", 3 1/2", 4", 4 1/2", 5", 5 1/2", 5 7/8", 6 5/8".

Hilong Sour Service Drill Pipe Grade:

HLDT-SS[®]75, HLDT-SS[®]95, HLDT-SS[®]105, HLDT-SS[®]110, HLDT-S[®]120, HLDT-S[®]125.

Table 8. Hilong Sour Service Drill Pipe Performance Data

Grade		HLDT-SS [®] 75	HLDT-SS [®] 95	HLDT-SS [®] 105	HLDT-SS [®] 110	HLDT-S [®] 120	HLDT-S [®] 125
Pipe Body	Yield Strength	75 – 95 ksi	95 – 110 ksi	105 – 120 ksi	110 – 125 ksi	120 – 135 ksi	125 – 140 ksi
		517 – 655 Mpa	655 – 758 Mpa	724 – 827 Mpa	758 – 862 Mpa	827 – 931 Mpa	862 – 965 Mpa
	Tensile Strength	95 – 115 ksi	105 – 130 ksi	115 – 140 ksi	120 – 145 ksi	≥130 ksi	≥135 ksi
		655 – 793 Mpa	724 – 896 Mpa	793 – 965 Mpa	827 – 1000 Mpa	≥896 Mpa	≥931 Mpa
	Toughness LCVN, 3/4 Size, 21°C	≥51 ft-lbf	≥59 ft-lbf	≥59 ft-lbf	≥59 ft-lbf	≥59 ft-lbf	≥59 ft-lbf
		≥70J	≥80J	≥80J	≥80J	≥80J	≥80J
	Hardness	≤24 HRC	18 – 27 HRC	21 – 29 HRC	21 – 32 HRC	≤34 HRC	≤34 HRC
	SSC Test (NACE TM0177)	Method A, Solution A, 85% SMYS, 720 Hours				Method A, Solution D, 85% SMYS, 720 Hours	
Tool Joint	Yield Strength	110 – 125 ksi				120 – 135 ksi	
		758 – 862 Mpa				827 – 931 Mpa	
	Tensile Strength	125 – 145 ksi				≥130 ksi	
		862 – 1000 Mpa				≥896 Mpa	
	Toughness LCVN, Full Size, 21°C	≥66 ft-lbf				≥66 ft-lbf	
		≥90J				≥90J	
Hardness	≤32 HRC				≤34 HRC		
SSC Test (NACE TM0177)	Method A, Solution A, 65% SMYS, 720 Hours				Method A, Solution D, 65% SMYS, 720 Hours		

■ Product Size/Grade

Hilong Sour Service HWDP Size: 3 1/2", 4", 4 1/2", 5", 5 1/2", 5 7/8", 6 5/8".

Hilong Sour Service HWDP Grade: HLHW-SS[®]75 and HLHW-SS[®]90.

Table 9. Hilong Sour Service HWDP Data

Grade		HLHW-SS [®] 75	HLHW-SS [®] 90
Pipe Body	Yield Strength	75 – 95 ksi	90 – 105 ksi
		517 – 655 Mpa	621 – 724 Mpa
	Tensile Strength	95 – 115 ksi	100 – 120 ksi
		655 – 793 Mpa	689 – 827 Mpa
	Toughness LCVN, Full Size, 21°C	≥55 ft-lbf	≥55 ft-lbf
		≥75J	≥75J
	Hardness	≤24 HRC	≤27 HRC
	SSC Test (NACE TM0177)	Method A, Solution A, 85% SMYS, 720 Hours	
Tool Joint	Yield Strength	110 – 125 ksi	
		758 – 862 Mpa	
	Tensile Strength	125 – 145 ksi	
		862 – 1000 Mpa	
	Toughness LCVN, Full Size, 21°C	≥66 ft-lbf	
		≥90J	
Hardness	≤32 HRC		
SSC Test (NACE TM0177)	Method A, Solution A, 65% SMYS, 720 Hours		

Hilong Non-Slip-Crush Drill Pipe

Product Introduction

Hilong Non-Slip-Crush (NSC) drill pipe is specially designed for solving problems such as the damage to the drill pipe body by the slip, the low operation efficiency of double-elevator, and the high labor intensity in the operation of TIH and TOH. This product adds one more shoulder positioned close to the box end based on normal API standard drill pipe. During the trip operation, drill string is set at the toothless pneumatic slip, and its weight is supported by the bearing slider of the slip along the axial direction. Besides, this product can afford a convenient way for make-up and break-out by raising its position.

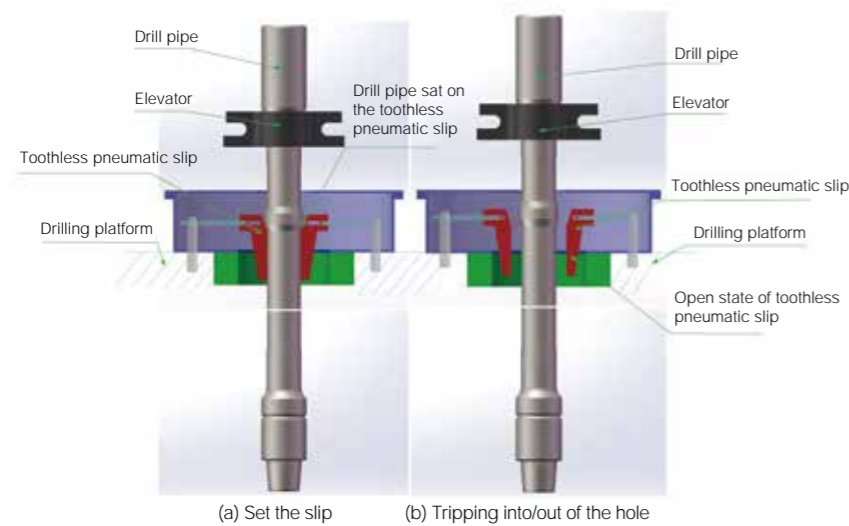

Product Advantage

Compared to standard drill pipe, Hilong NSC drill pipe has advantages as follows:

- It completely avoids the slip crush on drill pipe body when associated with toothless pneumatic slip, thus extend the drill pipe service life;
- It changes from the traditional double-elevator into single-elevator in the operation of TIH and TOH, which bring the advantage with no need for removing and hanging the elevator frequently. At the same time, a higher box tool joint position design can lead to the make and break more convenient, lower the labor's intensity; and it improves the safety of operation;
- Improving about 15% efficiency of TIH and TOH which compared with double-elevator, reducing non-drilling time, lowering the cost of operation;
- Reducing the sticking risk of drill pipe effectively, lowering the frictional resistance remarkably.

Product Specification

Size Range: 4", 4 1/2", 5", 5 1/2", 5 7/8", 6 5/8" etc.

Steel Grade: G105, S135, HLDT-SH®V150, HLDT-SH®U165.

Well Condition

More suitable for harsh conditions, including deep well, super deep well, offshore well, horizontal well, extended reach well, etc.



Hilong Slip-Protected Drill Pipe

Product Introduction

In order to reduce tripping time in the drilling process to improve drilling efficiency, "one elevator one slip" is the general tripping mode. The pipe body within the range of 600mm-900mm under the box end is always injured by using slip and cause "washouts" in pipe body. The slip transverse and longitudinal loads beared by drill pipe are higher and higher along with drilling depth increasing, complicated geological conditions and offshore drilling. Higher slip crushing capability of the pipe body is required. To solve these problems, Hilong designed and manufactured slip-proof drill pipe, the long, thick-walled upset section is designed on the box end.

Product Advantage

- Improving drill pipe slip crushing capability. Take 5" 19.50lb/ft G105 for example, the drill pipe crushing capability increased by 140%;
- Fatigue test proved that, because of slip injury, the fatigue life of ordinary drill pipe decreased by 60%. The fatigue life of slip-proof drill pipe (slip crush protest drill pipe) increased more than 5 times in the same slip injury condition.

Product Specification

Size Range: 4", 4-1/2", 5", 5 1/2", 5 7/8", 6 5/8", 7 5/8".

Steel Grade: G105, S135, HLDT-SH®Z140, HLDT-SH®V150.

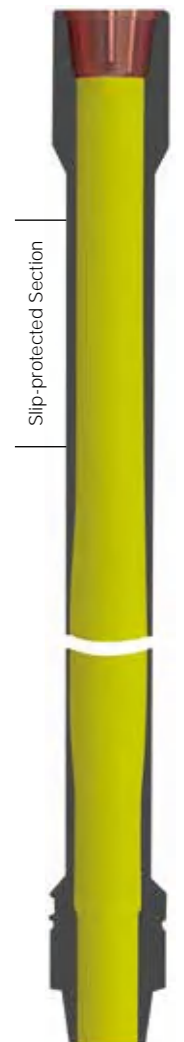
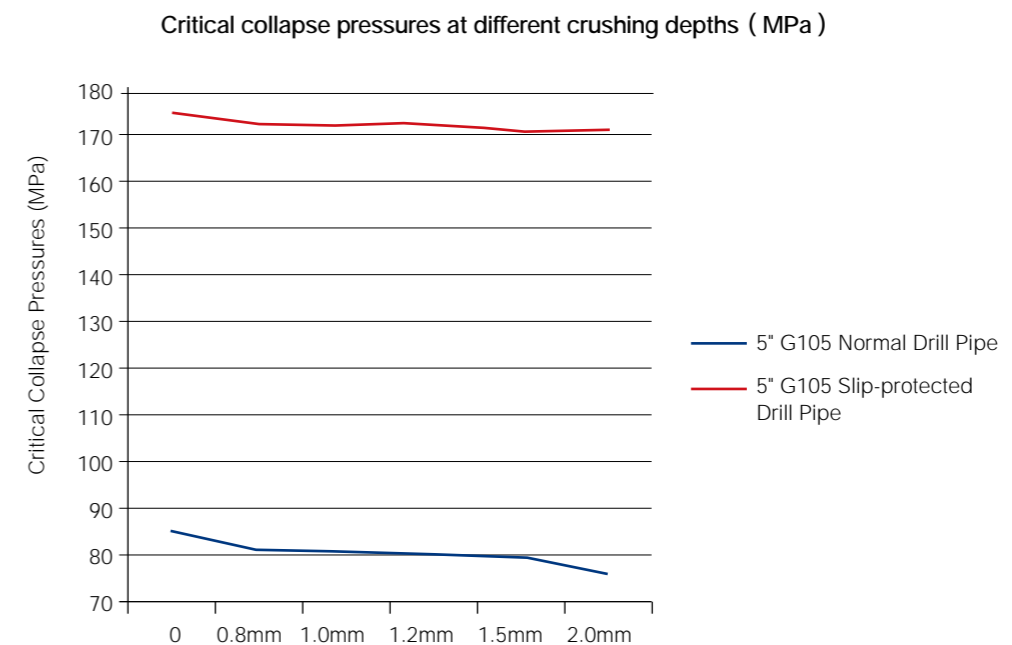

Hilong Flush Hole Drill Pipe

Product Introduction

Decreasing the hydro pressure loss to improve the hydro-efficiency is the key to improve drilling speed. Shanghai Hilong's proprietary flush-hole drill pipe is designed to be made-up with the drill pipe body using a special external upset with a large ID and the tool joint with Hilong double shouldered connections with a large ID also. The ID of the upset end and the tool joint are almost the same as that of the drill pipe body.



Product Advantage

- Special external upset technics effectively reduce stress concentration on the upset vanishing area, reduce fatigue failure possibility and improve anti-fatigue performance;
- The ID of the tool joint is almost the same as that of the drill pipe body;
- Decreasing annular pressure loss by 20%-50% and improving hydraulic efficiency and drilling speed;
- The flush-hole structure is suitable for continuous coring and wire-line coring.

Table 10. Hilong Flush Hole Drill Pipe Specification

Drill pipe OD (in)	Nominal weight (lb/ft)	Drill pipe body ID (in)	Upset typ	Grade	RSC type	Tool joint OD (in)	Tool joint ID (in)
4	14.00	3.340	EUE	S135	HLST®40	5.250	3.000
4	15.70	3.240	EUE	S135	HLST®42.5	5.250	3.000
4 1/2	16.60	3.826	EUE	S135	HLIST®46	6.000	3.750
4 1/2	16.60	3.826	EUE	S135	HLIDS®50	6.375	3.750
4 1/2	16.60	3.826	EUE	S135	HLIST®50	6.500	3.750
4 1/2	16.60	3.826	EUE	S135	HLST®52	6.500	3.750
5	19.50	4.276	EUE	S135	HLST®54	6.625	4.000
5	19.50	4.276	EUE	S135	HLIST®54	6.625	4.000
5 1/2	21.90	4.778	EUE	S135	HLST®57	7.000	4.250
5 1/2	21.90	4.778	EUE	S135	HLIST®57	7.000	4.250
5 7/8	23.40	5.153	EUE	S135	HLST®59	7.250	4.500
6 5/8	27.70	5.901	EUE	S135	HLST®72	8.500	5.500

Product Specification

Size Range: Normally 4 1/2", 5", 5 1/2", 5 7/8", 6 5/8" and 7 5/8".

Product Performance

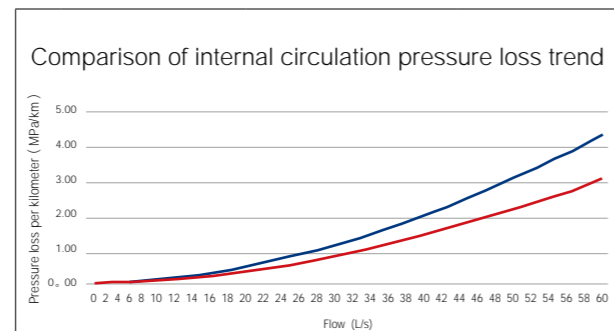

		API drill pipe	Hilong flush hole drill pipe	
Drill pipe body	OD	in	5.500	5.500
	Wall thickness	in	0.361	0.361
	ID	in	4.778	4.778
	Upset type		IEU	EUE
	Grade		S135	S135
	Tensile strength	lbs	786800	786800
Torsional strength	ft-lbs	91300	91300	
Tool joint	RSC type	API 5-1/2FH	HLST®57	
	OD	in	7.500	7.000
	ID	in	3.000	4.250
	Tensile strength	lbs	1925500	1243400
	Torsional strength	ft-lbs	87200	92900
Mud density	g/cm³		1.2	
Plastic viscosity	mpa·s		40	
Flow	L/s		20	

Hilong Double-Walled Drill Pipe

Product Introduction

Double-walled drill pipe is composed of two layers pipes. It is mainly used in reverse circulation drilling technique. The outer drill pipe is the transmission medium of torque and pressure, the space between outer and inner pipes is a channel for pumping circulating medium to well bottom, the inside channel of inner drill pipe returns the circulating medium and rock chips to the outside.

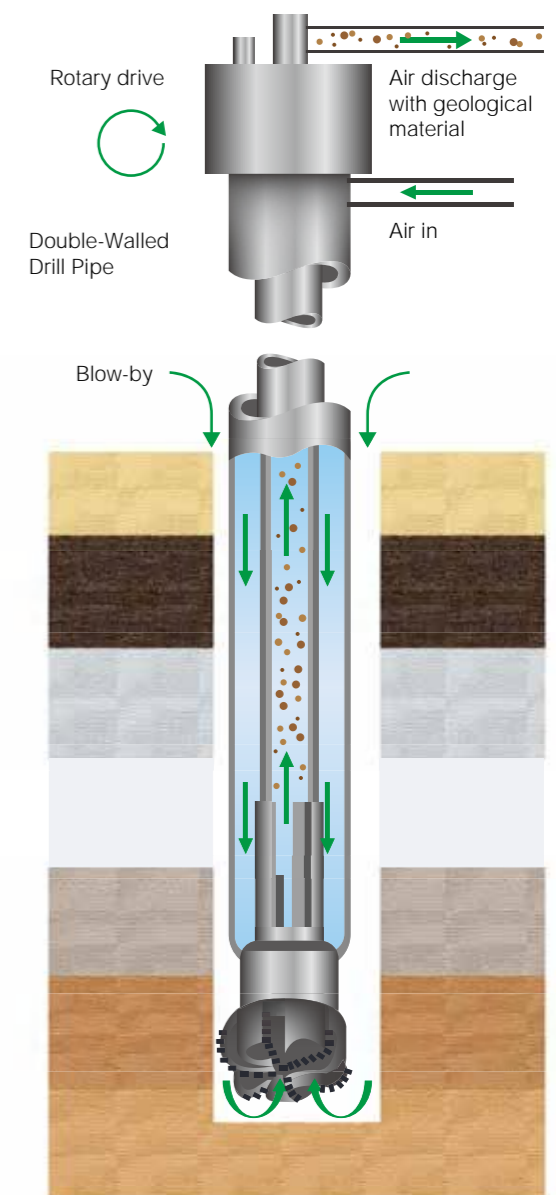

Product Advantage

- No wash out from the walls of a well, reservoir protection, no limit to drill collapse layer and loss formation;
- Less drilling fluid, smaller displacement and faster return speed, the hole is clean;
- Unique advantage in directional well, horizontal well and continuous sampling;
- Suitable for large hole drilling, improving drilling efficiency. New drilling techniques have been developed on the basis of double-walled drill pipe, the most typical representative of it are RDM (Reel Well Drilling Method) and RCCD (Reverse Circulation Centre Discharge).

Product Specification

Size Range (OD of external layer pipe):

Normally 5", 5 1/2", 5 7/8", 6 5/8", 7 5/8", 8 1/2", 9 1/2" and 10".

Hilong Arctic Service Drill Pipe

Product Introduction

Hilong arctic service drill pipe is a type of proprietary drill pipe with capability to perform in extreme cold regions. Service temperature - 60 °C and above.

Product Advantage

Compared to conventional API drill pipe, Hilong's proprietary Arctic Service Drill Pipe has a higher low temperature impact value and a lower brittleness transition temperature, resulting in better resistance to brittle fracture. Apparently, these arctic service products have better Fracture and fatigue resistance than normal API series if both of them are all used in room temperature, thus the service life could be improved evidently.

Product Specification

Size Range: Including all API size from 2 3/8 to 6 5/8 inches.

Steel Grade: HLDT-AS[®]75、HLDT-AS[®]95、HLDT-AS[®]105、HLDT-AS[®]135.

Product Performance

The mechanical requirements of different grades showed in the table, and the figures show the impact energy in different temperatures of HLDT-AS[®]135 drill pipe and the tool joint respectively:

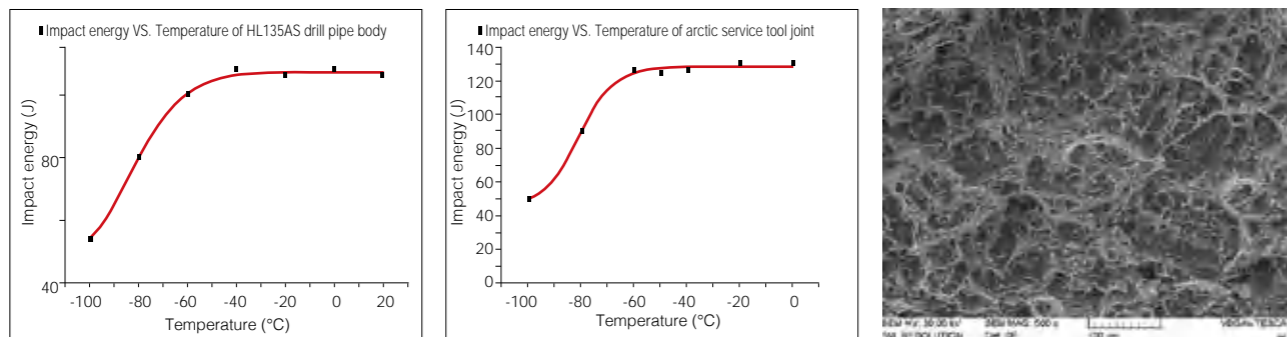

Table 11. Hilong Arctic Service Drill Pipe Performance Data

	Grade	Yield strength	Tensile strength	Charpy impact value (full size, -60°C or -75 °F, longitudinal)
Pipe body	HLDT-AS [®] 75	517/724 MPa	≥689 MPa	≥70 J
		75/105ksi	≥100ksi	≥52 ft-lb
	HLDT-AS [®] 95	655/862 MPa	≥724 MPa	≥70 J
		95/125ksi	≥105ksi	≥52 ft-lb
	HLDT-AS [®] 105	724/931 MPa	≥793 MPa	≥70 J
		105/135ksi	≥115ksi	≥52 ft-lb
HLDT-AS [®] 135	931/1138 MPa	≥1000 MPa	≥70 J	
	135/165ksi	≥145ksi	≥52 ft-lb	
Tool joint	—	827/1138 MPa	≥965 MPa	≥54 J
		120/165ksi	≥140ksi	≥40 ft-lb
Weld zone	—	10% greater than pipe body, failure must not occur on weld line		≥27 J
				≥26 ft-lb

Hilong Landing String Drill Pipe

Product Introduction

Hilong landing string drill pipe is typically used to land heavy casing strings in a deep-water environment. Designed at the aspects of the drill pipe structure, material strength, etc., so that the landing string drill pipe has sufficient tensile load capacity to meet the tensile requirements of large-size heavy-duty landing. The design of the Hilong landing string drill pipe ensures it has reduced weight, increased tool joint and pipe body tensile strength, and increased elevator lifting capacity, thereby improving the casing lowering capacity.

Product Structure and Advantage

- Thick-walled, high steel grade pipe body, to increase tensile and hoisting capacity.
- Increased drill pipe tool joint outer diameter/double outer diameter structure, to increase load capacity of the elevator.
- Slip-protected section, to increase slip crush damage capacity.
- According to customers' special requirements to provide the most appropriate landing string design.

Product Specification

Drill Pipe Size: 5", 5 1/2", 5 7/8", 6 5/8", 7 5/8".

Drill Pipe Grade: S135, HLDT-SH[®]Z140, HLDT-SH[®]V150, HLDT-SH[®]U165.

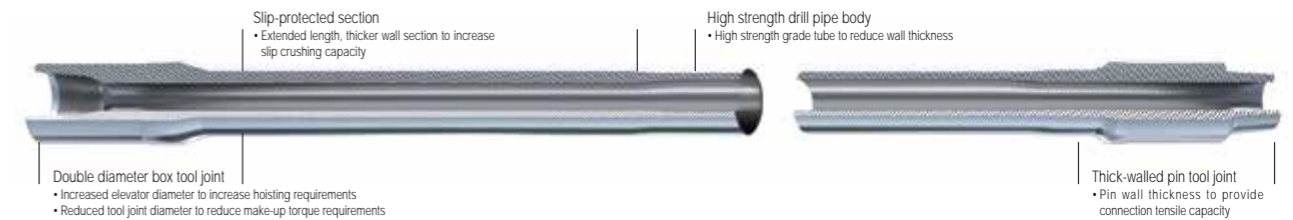

Table 12. Hilong Landing String Drill Pipe Data

Size in	Drill Pipe Body					Slip-Proof Section				Tool Joint				Elevator		Drill Pipe (with slip-protected section) Comprehensive tensile capacity lbs	
	OD in	Wall Thickness in	Grade	Tensile capacity lbs	Slip Crushing Load Capacity lbs	OD in	ID in	Yield Strength ksi	Slip Crushing Load Capacity lbs	R.S.C.	OD in	ID in	Yield Strength ksi	Tensile capacity lbs	Bore Diameter in		100% elevator carrying capacity lbs
5 1/2	5.500	0.750	S135	1510900	1239700	5.688	3.500	135	1749000	HLIST [®] 54	7.250	3.500	120	1508500	5.781	1653500	1508500
			HLDT-SH [®] V150	1678800	1377500			150	1943300				130	1634200			1634200
			HLDT-SH [®] U165	1846700	1515200			165	2137600				140	1760000			1653500
5 7/8	5.875	0.750	S135	1630200	1318900	6.000	3.875	135	1800100	HLIST [®] 57	7.500	3.500	120	1756500	6.094	1651500	1630200
			HLDT-SH [®] V150	1811300	1465500			150	2000100				130	1902900			1651500
			HLDT-SH [®] U165	1992500	1547300			165	2200100				140	2049300			1651500
6 5/8	6.625	0.813	S135	2002900	1575600	6.938	4.500	135	2325800	6-5/8FH	8.500	4.500	120	1896100	7.031	1970800	1896100
			HLDT-SH [®] V150	2225500	1750600			150	2584300				130	2054100			1970800
			HLDT-SH [®] U165	2448000	1925700			165	2842700				140	2212100			1970800

Note: 1. The slip-crushing load is calculated using a coefficient of friction of 0.08, slip length 20in, and a transverse load factor of 2.6.
2. Elevator capacity based on assumed Elevator Bore, no wear factor, and contact stress of 110ksi.

Hilong's Electronic Tag Drilling Tool and IoT Management System

Product Introduction

With Hilong's Electronic Tag Drilling Tool and IoT (Internet of Things) Management System, a radio frequency identification (RFID) tag is installed on each and every drilling tool product, and each tag acts as a unique "electronic ID card". The IoT Management System, combined with smart reader/writer devices, can efficiently and accurately realize full life cycle management of each drilling tool from production, warehouse in/out, allocation, use, maintenance, and testing to scrapping.

Product Advantages

- Accurate management – Manage the full life cycle process of each drill tool—production, warehouse in/out, allocation, use, maintenance, inspection, classification, and scrapping.
- Efficient and convenient – Automatically record drilling tool information, easy data viewing, entry and statistical analysis, user-friendly interface.
- Big data – Detailed information on the full life cycle of each drilling tool.
- Safe and reliable – Safety evaluation of each drilling tool, 100% reading of RFID tags.
- Reduced manual workload – No need to copy steel stamp number, no need to record length measurement and serial number at well site, reduction of manual paper files and records.

System Usage Scope

Drill pipes, heavy weight drill pipes, drill collars, drill bits, adapters, jars, shock absorbers, PDM drills, and other downhole tools or instruments.

Table 13. Hilong's Electronic Tag Drilling Tool Performance Specifications

Specification	Rating
Operating temperature	-60 °C ~ 220 °C
Pressure resistance	105 MPa
Anti-electromagnetic interference	Ultra-high frequency band (860~960 MHz)
Reading angle	Portable reader 180°, fixed reader 360°
Reading distance	Portable reader 0.1~1 m, fixed reader 1~2 m (customizable)
Applicable environment	Various oil and gas field environments
Electromagnetic radiation	Similar to mobile phones, harmless to humans

Product Solutions



Electronic Tag Drilling Tool IoT (Internet of Things) Management System

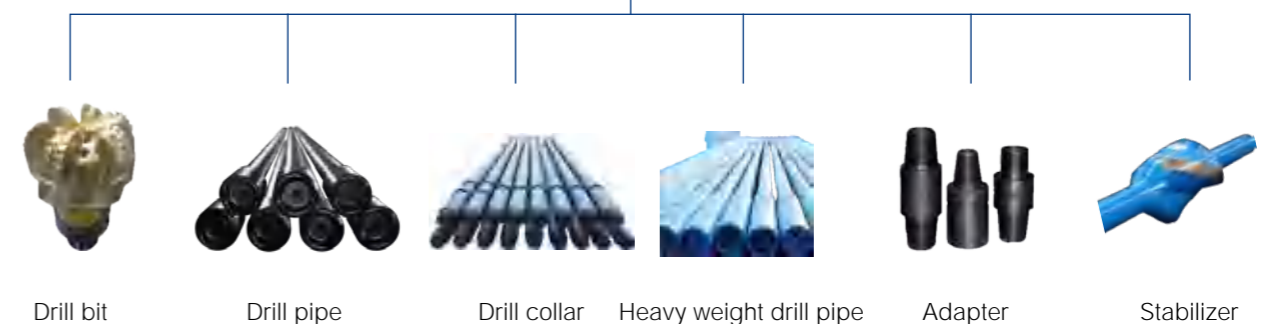

Hilong Efficient Cuttings Bed Clean Drill Tool

HLECDT™

Product Introduction

Hilong Efficient Cuttings Bed Clean Drill Tool (HLECDT™) is proprietary product which designed specifically to improve hole-cleaning performance in horizontal or complex non-conventional wells. It includes Hilong Efficient Cutting Bed Clean Drill Pipe (HLECDP™) and Hilong Efficient Cutting Bed Clean Heavy Weight Drill Pipe (HLECHWDP™). The upsets on their tube bodies have specially designed grooves. In these grooved sections the combination of rotational speed, flow rate and specially designed angles produce a number of mechanical and hydrodynamic effects that significantly improve hole-cleaning performance and greatly reduce the amount of non-productive time associated with a build-up of cuttings.

Product Advantage

- Cleaning efficiency improvement
 - Reduce cuttings bed height at given Flow Rate from 30% to 50%.
 - Improve Erosion Bed rate at given RPM more than 40%.
- Rig time saving
 - Circulating time to recover cuttings can be decreased by more than 50%.
 - Back reaming operations can be reduced or eliminated.
 - Increase rate of penetration.
- Frictional loading improvement
 - Torque & Drag loading can be decreased by 40%.
 - Reduction in Pressure Losses up to 50%.
- Reduce downhole failure risk and eliminate differential sticking.
- Cut down on well bore damage and provide better weight on bit.

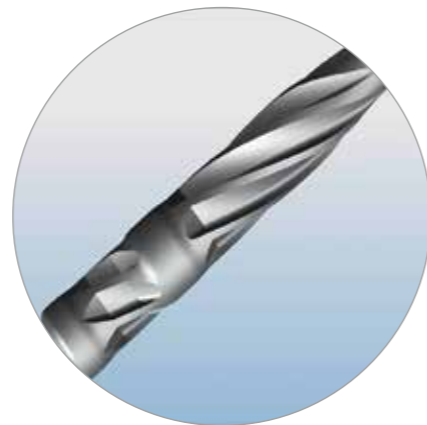

HLECDT™ Spiral groove local structure

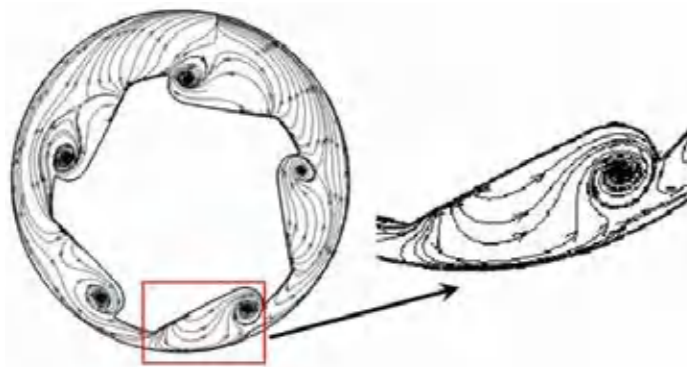

HLECDT™ Vortex near the groove



Hilong Large Size HDD (Horizontal Directional Drilling) Drill Pipe

Product Introduction

With the increase of drilling difficulty, the requirement of drill pipe is increasing at the same time. The whipping phenomenon and fracture failure of normal drill pipe in long distance horizontal directional drilling engineering is caused by the insufficient rigidity and buckling strength of the drill pipe. Galling caused by the difficulty of tool joint alignment is a common phenomenon in horizontal directional drilling engineering. Hilong designed and manufactured the HDD (horizontal directional drilling) drill pipe meet the large size need, at the same time the rigidity and the thrust also have improved. Special thread design and a guide section adding in the pin thread to prevent the possibility of galling and improve the fatigue capacity, meet the requirement of pipe line horizontal directional drilling engineering.

Product Advantage

- Large size, thick wall pipe body and high steel grade to improve the rigidity and the buckling strength;
- Special connection design using special large thread root radius and add a guide section to improve the fatigue capacity and prevent the possibility of galling;
- Special external upset technics effectively reduce stress concentration on the upset vanishing area, reduce fatigue failure possibility and improve anti-fatigue performance;
- Adding several joints of thick-walled drill pipe behind the over-sizing bit is a good choice to improve the rigidity of drill pipe, decline of drill pipe whipping and reduce fracture failure possibility.

Product Specification

Size Range: Normally 5 7/8", 6 5/8", 7 5/8", 8 5/8", 10", 10 3/4", 12 3/4" and 13 3/8".

Product Grade: G105, S135, HLDT-SH®Z140, HLDT-SH®V150, HLDT-SH®U165.

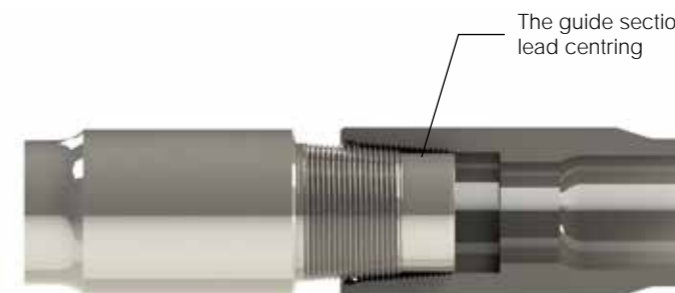

The guide section lead centring



Hilong Slim Drill Pipe

Product Introduction

The Hilong slim drill pipe is a non-standard drill pipe developed by Hilong in combination with pipe-end internal upsetting forming technology and high-performance premium connection. It can provide effective solution for small-hole drilling, short-radius horizontal well drilling, oil well workover and secondary exploitation.



Product Advantages

The tool joint outer diameter of Hilong slim drill pipe is close or equal to the outer diameter of the drill pipe body. It has the characteristics of small tool joint outer diameter and good drill pipe flexibility. It can be used in slim hole where conventional drill pipes cannot be used, and it is suitable for workover, window sidetracking and other operations.

The smooth outer wall of the drill pipe reduces the risk of sticking and the difficulty of releasing the pipe. Compared with the conventional drill pipe, it is more suitable for horizontal drilling.

Under the condition of the same borehole size, the reduced outer diameter of the tool joint increases the clearance between the drill string and the borehole wall, which makes the curvature of the kick off point larger, and can realize short radius and ultra-short radius drilling.

Table 14. Common specifications of Hilong slim drill pipe (SI units)

Drill Pipe Body OD (mm)	Wall thickness (mm)	Grade	Connection	Tool Joint OD (mm)	Tool Joint ID (mm)
60.33	7.11	G105	HLSD [®] 21	69.85	34.93
60.33	7.11	G105	HLMT [®] 2-3/8PAC	73.03	34.93
60.33	7.11	G105	HLIDS [®] 23	76.20	34.93
73.03	5.51	G105	HLMT [®] 2-7/8PAC	79.38	38.10
73.03	9.19	G105	HLMT [®] 2-7/8PAC	79.38	38.10
88.90	6.45	G105	HLST [®] 26	88.90	44.45
88.90	9.35	G105	HLST [®] 31	101.60	50.80
88.90	9.35	G105	HLSD [®] 33	104.78	57.15
101.60	6.65	G105	HLST [®] 31	101.60	50.80
101.60	8.38	S135	HLST [®] 36	114.30	61.91
114.30	6.88	G105	HLST [®] 36	114.30	61.93
114.30	8.56	S135	HLST [®] 40	133.35	68.26

Table 15. Common specifications of Hilong slim drill pipe (USC units)

Drill Pipe Body OD (in)	Nominal weight (lb/ft)	Grade	Connection	Tool Joint OD (in)	Tool Joint ID (in)
2 3/8	6.65	G105	HLSD [®] 21	2.750	1.375
2 3/8	6.65	G105	HLMT [®] 2-3/8PAC	2.875	1.375
2 3/8	6.65	G105	HLIDS [®] 23	3.000	1.375
2 7/8	6.85	G105	HLMT [®] 2-7/8PAC	3.125	1.500
2 7/8	10.40	G105	HLMT [®] 2-7/8PAC	3.125	1.500
3 1/2	9.50	G105	HLST [®] 26	3.500	1.750
3 1/2	13.30	G105	HLST [®] 31	4.000	2.000
3 1/2	13.30	G105	HLSD [®] 33	4.125	2.250
4	11.85	G105	HLST [®] 31	4.000	2.000
4	14.00	S135	HLST [®] 36	4.500	2.438
4 1/2	13.75	G105	HLST [®] 36	4.500	2.438
4 1/2	16.60	S135	HLST [®] 40	5.250	2.688

Appendix A

Tables in SI units

Table A.1 Commonly-used Drill Pipes Data

Pipe Body OD (mm)	Nominal Wall Thickness (mm)	Upset Type	Grade	RSC Type	Tool Joint	
					OD (mm)	ID (mm)
60.33	7.11	EU	E / X / G	NC26	85.73	44.45
60.33	7.11	EU	G / S / Z / V	HLIDS [®] 26	85.73	44.45
60.33	7.11	EU	S / Z / V	HLST [®] 26	85.73	44.45
60.33	7.11	IU	G / S	HLIDS [®] 23	76.20	34.93
60.33	7.11	IU	G / S	HLMT [®] 2-3/8PAC	73.03	34.93
73.03	9.19	EU	E	NC31	104.78	53.98
73.03	9.19	EU	X / G	NC31	104.78	50.80
73.03	9.19	EU	S	NC31	111.13	41.28
73.03	9.19	EU	G / S / Z / V	HLIDS [®] 31	104.78	50.80
73.03	9.19	EU	G / S / Z / V	HLST [®] 31	104.78	50.80
73.03	9.19	IU	E / X / G	HLIDS [®] 26	85.73	44.45
73.03	9.19	IU	E / X / G	HLMT [®] 2-7/8PAC	79.38	38.10
73.03	9.19	IU	E / X / G	HLST [®] 26	85.73	44.45
88.90	9.35	EU	E	NC38	120.65	68.26
88.90	9.35	EU	X	NC38	127.00	65.09
88.90	9.35	EU	G	NC38	127.00	61.91
88.90	9.35	EU	S	NC38	127.00	53.98
88.90	9.35	EU	G	HLIDS [®] 38	127.00	65.09
88.90	9.35	EU	S / Z	HLIDS [®] 38	127.00	61.91
88.90	9.35	EU	V	HLIDS [®] 38	127.00	53.98
88.90	9.35	EU	G	HLMT [®] 38	120.65	68.26
88.90	9.35	EU	S / Z / V	HLMT [®] 38	120.65	65.09
88.90	9.35	EU	G	HLST [®] 36	120.65	61.91
88.90	9.35	EU	S / Z / V	HLST [®] 36	120.65	53.98
88.90	9.35	EU	G	HLST [®] 39	123.83	71.44
88.90	9.35	EU	S	HLST [®] 39	123.83	68.26
88.90	9.35	EU	Z / V	HLST [®] 39	127.00	65.09
88.90	9.35	EU	G	HLIST [®] 38	120.65	68.26
88.90	9.35	EU	S / Z / V	HLIST [®] 38	120.65	65.09
88.90	9.35	EU	G / S / Z / V	HLIST [®] 39	123.83	68.26
88.90	9.35	IU	E / X / G	HLIDS [®] 31	104.78	50.80

Pipe Body OD (mm)	Nominal Wall Thickness (mm)	Upset Type	Grade	RSC Type	Tool Joint	
					OD (mm)	ID (mm)
88.90	9.35	IU	S	HLIDS®31	107.95	50.80
88.90	9.35	IU	E	HLST®31	101.60	57.15
88.90	9.35	IU	X / G / S	HLST®31	104.78	50.80
88.90	11.40	EU	E	NC38	127.00	65.09
88.90	11.40	EU	X	NC38	127.00	61.91
88.90	11.40	EU	G	NC38	127.00	53.98
88.90	11.40	EU	S	NC40	139.70	57.15
88.90	11.40	EU	E / X	HLIDS®38	127.00	65.09
88.90	11.40	EU	G	HLIDS®38	127.00	61.91
88.90	11.40	EU	S / Z / V	HLIDS®38	127.00	53.98
88.90	11.40	EU	G	HLMT®38	120.65	65.09
88.90	11.40	EU	S / Z	HLMT®38	123.83	61.91
88.90	11.40	EU	V	HLMT®38	127.00	57.15
88.90	11.40	EU	X	HLST®36	120.65	65.09
88.90	11.40	EU	G	HLST®36	120.65	61.91
88.90	11.40	EU	S / Z / V	HLST®36	120.65	53.98
88.90	11.40	EU	G / S	HLST®39	127.00	65.09
88.90	11.40	EU	Z / V	HLST®39	127.00	61.91
88.90	11.40	EU	G	HLIST®38	120.65	65.09
88.90	11.40	EU	S / Z / V	HLIST®38	120.65	61.91
88.90	11.40	EU	G / S / Z / V	HLIST®39	123.83	65.09
101.60	8.38	IU	E	NC40	133.35	71.44
101.60	8.38	IU	X	NC40	133.35	68.26
101.60	8.38	IU	G	NC40	139.70	61.91
101.60	8.38	IU	S	NC40	139.70	50.80
101.60	8.38	IU	E / X	HLIDS®38	127.00	68.26
101.60	8.38	IU	G	HLIDS®38	127.00	65.09
101.60	8.38	IU	S	HLIDS®38	127.00	61.91
101.60	8.38	IU	E / X	HLIDS®40	133.35	71.44
101.60	8.38	IU	G	HLIDS®40	133.35	68.26
101.60	8.38	IU	S / Z / V	HLIDS®40	133.35	65.09
101.60	8.38	IU	G	HLMT®38	127.00	65.09
101.60	8.38	IU	S	HLMT®38	127.00	61.91
101.60	8.38	IU	G	HLMT®40	133.35	68.26
101.60	8.38	IU	S / Z / V	HLMT®40	133.35	65.09
101.60	8.38	IU	E / X	HLST®36	120.65	65.09

Pipe Body OD (mm)	Nominal Wall Thickness (mm)	Upset Type	Grade	RSC Type	Tool Joint	
					OD (mm)	ID (mm)
101.60	8.38	IU	G	HLST®36	120.65	61.91
101.60	8.38	IU	S	HLST®36	120.65	53.98
101.60	8.38	IU	E / X	HLST®39	123.83	71.44
101.60	8.38	IU	G	HLST®39	123.83	68.26
101.60	8.38	IU	S	HLST®39	123.83	65.09
101.60	8.38	IU	Z / V	HLST®39	127.00	65.09
101.60	8.38	IU	G	HLIST®38	120.65	65.09
101.60	8.38	IU	S	HLIST®38	120.65	61.91
101.60	8.38	IU	G	HLIST®39	123.83	68.26
101.60	8.38	IU	S / Z / V	HLIST®39	123.83	65.09
101.60	9.65	IU	E / X	HLIDS®40	133.35	71.44
101.60	9.65	IU	G	HLIDS®40	133.35	68.26
101.60	9.65	IU	S	HLIDS®40	133.35	65.09
101.60	9.65	IU	Z / V	HLIDS®40	139.70	61.91
101.60	9.65	IU	G	HLMT®40	133.35	68.26
101.60	9.65	IU	S / Z	HLMT®40	133.35	65.09
101.60	9.65	IU	V	HLMT®40	133.35	61.91
101.60	9.65	IU	G	HLST®39	123.83	65.09
101.60	9.65	IU	S / Z / V	HLST®39	127.00	61.91
101.60	9.65	IU	G / S	HLST®40	133.35	68.26
101.60	9.65	IU	Z / V	HLST®40	136.53	65.09
101.60	9.65	IU	G	HLIST®39	123.83	65.09
101.60	9.65	IU	S / Z / V	HLIST®39	127.00	61.91
114.30	8.56	IEU	E	NC46	158.75	82.55
114.30	8.56	IEU	X / G	NC46	158.75	76.20
114.30	8.56	IEU	S	NC46	158.75	69.85
114.30	8.56	IEU	E / X / G	HLIDS®46	152.40	82.55
114.30	8.56	IEU	S / Z / V	HLIDS®46	152.40	76.20
114.30	8.56	IEU	G / S / Z / V	HLMT®46	152.40	82.55
114.30	8.56	IEU	G / S / Z / V	HLST®46	152.40	82.55
114.30	8.56	IEU	G / S / Z / V	HLIST®46	152.40	82.55
114.30	8.56	IEU	G	HLIDS®40	133.35	68.26
114.30	8.56	IEU	S	HLIDS®40	133.35	65.09
114.30	8.56	IEU	G / S	HLST®40	133.45	68.26
114.30	10.92	IEU	E	NC46	158.75	76.20
114.30	10.92	IEU	X	NC46	158.75	69.85

Pipe Body OD (mm)	Nominal Wall Thickness (mm)	Upset Type	Grade	RSC Type	Tool Joint	
					OD (mm)	ID (mm)
114.30	10.92	IEU	G	NC46	158.75	63.50
114.30	10.92	IEU	S	NC46	158.75	57.15
114.30	10.92	IEU	E / X / G	HLIDS®46	152.40	76.20
114.30	10.92	IEU	S / Z / V	HLIDS®46	152.40	69.85
114.30	10.92	IEU	G / S / Z / V	HLMT®46	152.40	76.20
114.30	10.92	IEU	G / S / Z / V	HLST®46	152.40	76.20
114.30	10.92	IEU	G / S / Z / V	HLIST®46	152.40	76.20
127.00	9.19	IEU	E	NC50	168.28	95.25
127.00	9.19	IEU	X	NC50	168.28	88.90
127.00	9.19	IEU	G	NC50	168.28	82.55
127.00	9.19	IEU	S	NC50	168.28	69.85
127.00	9.19	IEU	E	HLIDS®50	165.10	95.25
127.00	9.19	IEU	X	HLIDS®50	168.28	95.25
127.00	9.19	IEU	G	HLIDS®50	168.28	88.90
127.00	9.19	IEU	S / Z / V	HLIDS®50	168.28	82.55
127.00	9.19	IEU	G / S / Z / V	HLMT®50	168.28	88.90
127.00	9.19	IEU	E / X	HLST®46	152.40	88.90
127.00	9.19	IEU	G	HLST®46	152.40	82.55
127.00	9.19	IEU	S / Z / V	HLST®46	152.40	76.20
127.00	9.19	IEU	E / X / G	HLST®52	165.10	101.60
127.00	9.19	IEU	S / Z / V	HLST®52	165.10	95.25
127.00	9.19	IEU	G / S / Z	HLIST®46	152.40	88.90
127.00	9.19	IEU	S / Z / V	HLIST®46	158.75	82.55
127.00	9.19	IEU	G	HLIST®50	165.10	101.60
127.00	9.19	IEU	S / Z / V	HLIST®50	165.10	95.25
127.00	12.70	IEU	E	NC50	168.28	88.90
127.00	12.70	IEU	X	NC50	168.28	76.20
127.00	12.70	IEU	G	NC50	168.28	69.85
127.00	12.70	IEU	S	5-1/2FH	184.15	82.55
127.00	12.70	IEU	E	HLIDS®50	165.10	95.25
127.00	12.70	IEU	X / G	HLIDS®50	168.28	88.90
127.00	12.70	IEU	S / Z / V	HLIDS®50	168.28	76.20
127.00	12.70	IEU	G	HLMT®50	168.28	88.90
127.00	12.70	IEU	S / Z / V	HLMT®50	168.28	76.20
127.00	12.70	IEU	E	HLST®46	152.40	88.90
127.00	12.70	IEU	X	HLST®46	152.40	82.55

Pipe Body OD (mm)	Nominal Wall Thickness (mm)	Upset Type	Grade	RSC Type	Tool Joint	
					OD (mm)	ID (mm)
127.00	12.70	IEU	G	HLST®46	158.75	76.20
127.00	12.70	IEU	S	HLST®46	158.75	69.85
127.00	12.70	IEU	E / X / G	HLST®52	168.28	95.25
127.00	12.70	IEU	S / Z / V	HLST®52	168.28	82.55
127.00	12.70	IEU	G	HLIST®50	168.28	95.25
127.00	12.70	IEU	S / Z / V	HLIST®50	168.28	82.55
139.70	9.17	IEU	E	5-1/2FH	177.80	101.60
139.70	9.17	IEU	X	5-1/2FH	177.80	95.25
139.70	9.17	IEU	G	5-1/2FH	184.15	88.90
139.70	9.17	IEU	S	5-1/2FH	190.50	76.20
139.70	9.17	IEU	E / X / G / S / Z / V / U	HLIDS®5-1/2FH	177.80	101.60
139.70	9.17	IEU	G / S / Z / V / U	HLMT®5-1/2FH	177.80	101.60
139.70	9.17	IEU	E / X / G	HLST®52	165.10	101.60
139.70	9.17	IEU	S	HLST®52	168.28	95.25
139.70	9.17	IEU	E / X / G	HLST®54	168.28	107.95
139.70	9.17	IEU	S	HLST®54	171.45	101.60
139.70	9.17	IEU	Z / V	HLST®54	174.63	98.43
139.70	9.17	IEU	G / S / Z / V / U	HLST®57	177.80	107.95
139.70	9.17	IEU	G	HLIST®54	168.28	107.95
139.70	9.17	IEU	S / Z / V	HLIST®54	171.45	101.60
139.70	9.17	IEU	G / S / Z / V / U	HLIST®57	177.80	107.95
139.70	10.54	IEU	E	5-1/2FH	177.80	101.60
139.70	10.54	IEU	X / G	5-1/2FH	184.15	88.90
139.70	10.54	IEU	S	5-1/2FH	190.50	76.20
139.70	10.54	IEU	E / X / G	HLIDS®5-1/2FH	177.80	101.60
139.70	10.54	IEU	S / Z / V / U	HLIDS®5-1/2FH	184.15	95.25
139.70	10.54	IEU	G / S	HLMT®5-1/2FH	177.80	101.60
139.70	10.54	IEU	Z / V / U	HLMT®5-1/2FH	184.15	95.25
139.70	10.54	IEU	G	HLST®54	171.45	101.60
139.70	10.54	IEU	S / Z / V	HLST®54	174.63	95.25
139.70	10.54	IEU	G / S / Z / V / U	HLST®57	180.98	101.60
139.70	10.54	IEU	G	HLIST®54	171.45	101.60
139.70	10.54	IEU	S / Z / V	HLIST®54	174.63	95.25
139.70	10.54	IEU	G / S / Z / V / U	HLIST®57	180.98	101.60
149.23	9.17	IEU	S / Z / V / U	HLIDS®5-1/2FH	184.15	101.60
149.23	9.17	IEU	S / Z / V / U	HLMT®5-1/2FH	184.15	101.60

Pipe Body OD (mm)	Nominal Wall Thickness (mm)	Upset Type	Grade	RSC Type	Tool Joint	
					OD (mm)	ID (mm)
149.23	9.17	IEU	S / Z / V / U	HLST®57	177.80	104.78
149.23	9.17	IEU	S / Z / V / U	HLIST®57	177.80	104.78
149.23	10.54	IEU	S / Z / V / U	HLIDS®5-1/2FH	184.15	98.43
149.23	10.54	IEU	S / Z / V / U	HLMT®5-1/2FH	184.15	98.43
149.23	10.54	IEU	S / Z / V / U	HLST®57	184.15	101.60
149.23	10.54	IEU	S / Z / V / U	HLIST®57	184.15	101.60
168.28	8.38	IEU	E / X	6-5/8FH	203.20	127.00
168.28	8.38	IEU	G	6-5/8FH	209.55	120.65
168.28	8.38	IEU	S	6-5/8FH	209.55	107.95
168.28	8.38	IEU	E / X / G / S / Z / V / U	HLIDS®6-5/8FH	203.20	127.00
168.28	9.19	IEU	E	6-5/8FH	203.20	127.00
168.28	9.19	IEU	X / G	6-5/8FH	209.55	120.65
168.28	9.19	IEU	S	6-5/8FH	215.90	107.95
168.28	9.19	IEU	E / X / G	HLIDS®6-5/8FH	203.20	127.00
168.28	9.19	IEU	S / Z / V / U	HLIDS®6-5/8FH	209.55	120.65

Notes:

Abbreviated steel grade: E - E75; X - X95; G - G105; S - S135; Z - HLDT-SH®Z140; V - HLDT-SH®V150; U - HLDT-SH®U165.

The tool joint OD and ID listed above are the dimensions commonly used in drilling. It can be customized according to the actual well conditions and user requirements.

Table A.2 Commonly-used Sour Service Drill Pipes Data

Pipe Body OD (mm)	Nominal Wall Thickness (mm)	Upset Type	Grade	RSC Type	Tool Joint	
					OD (mm)	ID (mm)
60.33	7.11	EU	SS75 / SS95 / SS105 / HL110SS	NC26	85.73	44.45
60.33	7.11	EU	SS75 / SS95 / SS105 / HL110SS / HL120S	HLIDS®26	85.73	44.45
60.33	7.11	EU	SS105 / HL110SS / HL120S	HLST®26	85.73	44.45
60.33	7.11	IU	SS105 / HL110SS / HL120S	HLIDS®23	76.20	34.93
60.33	7.11	IU	SS105 / HL110SS / HL120S	HLMT®2-3/8PAC	73.03	34.93
73.03	9.19	EU	SS75	NC31	104.78	53.98
73.03	9.19	EU	SS95 / SS105 / HL110SS	NC31	104.78	50.80
73.03	9.19	EU	SS105 / HL110SS / HL120S	HLIDS®31	104.78	50.80
73.03	9.19	EU	SS105 / HL110SS / HL120S	HLST®31	104.78	50.80
73.03	9.19	IU	SS75 / SS95 / SS105 / HL110SS	HLIDS®26	85.73	44.45
73.03	9.19	IU	SS75 / SS95 / SS105 / HL110SS	HLMT®2-7/8PAC	79.38	38.10
73.03	9.19	IU	SS75 / SS95 / SS105 / HL110SS	HLST®26	85.73	44.45
88.90	9.35	EU	SS75	NC38	120.65	68.26
88.90	9.35	EU	SS95	NC38	127.00	65.09
88.90	9.35	EU	SS105 / HL110SS	NC38	127.00	61.91
88.90	9.35	EU	SS105 / HL110SS / HL120S	HLIDS®38	127.00	65.09
88.90	9.35	EU	SS105 / HL110SS / HL120S	HLMT®38	123.83	65.09
88.90	9.35	EU	SS105 / HL110SS / HL120S	HLST®36	120.65	57.15
88.90	9.35	EU	SS105 / HL110SS / HL120S	HLST®39	123.83	68.26
88.90	9.35	EU	SS105 / HL110SS / HL120S	HLIST®38	120.65	65.09
88.90	9.35	EU	SS105 / HL110SS / HL120S	HLIST®39	123.83	68.26
88.90	9.35	IU	SS75 / SS95 / SS105 / HL110SS	HLIDS®31	104.78	50.80
88.90	9.35	IU	SS75 / SS95 / SS105 / HL110SS	HLST®31	104.78	50.80
88.90	11.40	EU	SS75	NC38	127.00	65.09
88.90	11.40	EU	SS95	NC38	127.00	61.91
88.90	11.40	EU	SS105 / HL110SS	NC38	127.00	53.98
88.90	11.40	EU	SS105 / HL110SS / HL120S	HLIDS®38	127.00	61.91
88.90	11.40	EU	SS105 / HL110SS / HL120S	HLMT®38	123.83	61.91
88.90	11.40	EU	SS105 / HL110SS / HL120S	HLST®36	120.65	53.98
88.90	11.40	EU	SS105 / HL110SS / HL120S	HLST®39	127.00	65.09
88.90	11.40	EU	SS105 / HL110SS / HL120S	HLIST®38	120.65	61.91
88.90	11.40	EU	SS105 / HL110SS / HL120S	HLIST®39	123.83	65.09
101.60	8.38	IU	SS75	NC40	133.35	71.44
101.60	8.38	IU	SS95	NC40	133.35	68.26

Pipe Body OD (mm)	Nominal Wall Thickness (mm)	Upset Type	Grade	RSC Type	Tool Joint	
					OD (mm)	ID (mm)
101.60	8.38	IU	SS105 / HL110SS	NC40	139.70	61.91
101.60	8.38	IU	SS105 / HL110SS / HL120S / HL125S	HLIDS®38	127.00	65.09
101.60	8.38	IU	SS105 / HL110SS / HL120S / HL125S	HLIDS®40	133.35	68.26
101.60	8.38	IU	SS105 / HL110SS / HL120S / HL125S	HLMT®38	127.00	65.09
101.60	8.38	IU	SS105 / HL110SS / HL120S / HL125S	HLMT®40	133.35	68.26
101.60	8.38	IU	SS105 / HL110SS / HL120S / HL125S	HLST®36	120.65	53.98
101.60	8.38	IU	SS105 / HL110SS / HL120S / HL125S	HLST®39	123.83	65.09
101.60	8.38	IU	SS105 / HL110SS / HL120S / HL125S	HLIST®38	120.65	61.91
101.60	8.38	IU	SS105 / HL110SS / HL120S / HL125S	HLIST®39	123.83	65.09
101.60	9.65	IU	SS105 / HL110SS / HL120S / HL125S	HLIDS®40	133.35	65.09
101.60	9.65	IU	SS105 / HL110SS / HL120S / HL125S	HLMT®40	133.35	65.09
101.60	9.65	IU	SS105 / HL110SS / HL120S / HL125S	HLST®39	123.83	65.09
101.60	9.65	IU	SS105 / HL110SS / HL120S / HL125S	HLST®40	133.35	68.26
101.60	9.65	IU	SS105 / HL110SS / HL120S / HL125S	HLIST®39	123.83	65.09
114.30	8.56	IEU	SS75	NC46	158.75	82.55
114.30	8.56	IEU	SS95 / SS105 / HL110SS	NC46	158.75	76.20
114.30	8.56	IEU	HL120S / HL125S	NC46	158.75	69.85
114.30	8.56	IEU	SS105 / HL110SS / HL120S / HL125S	HLIDS®46	152.40	82.55
114.30	8.56	IEU	SS105 / HL110SS / HL120S / HL125S	HLMT®46	152.40	82.55
114.30	8.56	IEU	SS105 / HL110SS / HL120S / HL125S	HLST®46	152.40	82.55
114.30	8.56	IEU	SS105 / HL110SS / HL120S / HL125S	HLIST®46	152.40	82.55
114.30	8.56	IEU	SS105 / HL110SS / HL120S / HL125S	HLIDS®40	133.35	65.09
114.30	8.56	IEU	SS105 / HL110SS / HL120S / HL125S	HLST®40	133.45	68.26
114.30	10.92	IEU	SS75	NC46	158.75	76.20
114.30	10.92	IEU	SS95	NC46	158.75	69.85
114.30	10.92	IEU	SS105 / HL110SS	NC46	158.75	63.50
114.30	10.92	IEU	HL120S / HL125S	NC46	158.75	57.15
114.30	10.92	IEU	SS105 / HL110SS / HL120S / HL125S	HLIDS®46	152.40	76.20
114.30	10.92	IEU	SS105 / HL110SS / HL120S / HL125S	HLMT®46	152.40	76.20
114.30	10.92	IEU	SS105 / HL110SS / HL120S / HL125S	HLST®46	152.40	76.20
114.30	10.92	IEU	SS105 / HL110SS / HL120S / HL125S	HLIST®46	152.40	76.20
127.00	9.19	IEU	SS75	NC50	168.28	95.25
127.00	9.19	IEU	SS95	NC50	168.28	88.90
127.00	9.19	IEU	SS105 / HL110SS	NC50	168.28	82.55
127.00	9.19	IEU	SS105 / HL110SS / HL120S / HL125S	HLIDS®50	168.28	88.90
127.00	9.19	IEU	SS105 / HL110SS / HL120S / HL125S	HLMT®50	168.28	88.90

Pipe Body OD (mm)	Nominal Wall Thickness (mm)	Upset Type	Grade	RSC Type	Tool Joint	
					OD (mm)	ID (mm)
127.00	9.19	IEU	SS105 / HL110SS / HL120S / HL125S	HLST®46	152.40	82.55
127.00	9.19	IEU	SS75 / SS95 / SS105 / HL110SS	HLST®52	165.10	101.60
127.00	9.19	IEU	HL120S / HL125S	HLST®52	165.10	95.25
127.00	9.19	IEU	SS105 / HL110SS / HL120S / HL125S	HLIST®46	152.40	88.90
127.00	9.19	IEU	SS105 / HL110SS / HL120S / HL125S	HLIST®50	165.10	95.25
127.00	12.70	IEU	SS75	NC50	168.28	88.90
127.00	12.70	IEU	SS95	NC50	168.28	76.20
127.00	12.70	IEU	SS105 / HL110SS	NC50	168.28	69.85
127.00	12.70	IEU	SS105 / HL110SS / HL120S / HL125S	HLIDS®50	168.28	76.20
127.00	12.70	IEU	SS105 / HL110SS / HL120S / HL125S	HLMT®50	168.28	76.20
127.00	12.70	IEU	SS105 / HL110SS / HL120S / HL125S	HLST®46	158.75	69.85
127.00	12.70	IEU	SS105 / HL110SS / HL120S / HL125S	HLST®52	168.28	85.73
127.00	12.70	IEU	SS105 / HL110SS / HL120S / HL125S	HLIST®50	168.28	88.90
139.70	9.17	IEU	SS75	5-1/2FH	177.80	101.60
139.70	9.17	IEU	SS95	5-1/2FH	177.80	95.25
139.70	9.17	IEU	SS105 / HL110SS	5-1/2FH	184.15	88.90
139.70	9.17	IEU	SS105 / HL110SS / HL120S / HL125S	HLIDS®5-1/2FH	177.80	101.60
139.70	9.17	IEU	SS105 / HL110SS / HL120S / HL125S	HLMT®5-1/2FH	177.80	101.60
139.70	9.17	IEU	SS105 / HL110SS / HL120S / HL125S	HLST®52	165.10	95.25
139.70	9.17	IEU	SS105 / HL110SS / HL120S / HL125S	HLST®54	171.45	101.60
139.70	9.17	IEU	SS105 / HL110SS / HL120S / HL125S	HLST®57	177.80	104.78
139.70	9.17	IEU	SS105 / HL110SS / HL120S / HL125S	HLIST®54	168.28	101.60
139.70	9.17	IEU	SS105 / HL110SS / HL120S / HL125S	HLIST®57	177.80	104.78
139.70	10.54	IEU	SS75	5-1/2FH	177.80	101.60
139.70	10.54	IEU	SS95 / SS105 / HL110SS	5-1/2FH	184.15	88.90
139.70	10.54	IEU	SS105 / HL110SS / HL120S / HL125S	HLIDS®5-1/2FH	177.80	101.60
139.70	10.54	IEU	SS105 / HL110SS / HL120S / HL125S	HLMT®5-1/2FH	177.80	101.60
139.70	10.54	IEU	SS105 / HL110SS / HL120S / HL125S	HLST®54	174.63	98.43
139.70	10.54	IEU	SS105 / HL110SS / HL120S / HL125S	HLST®57	177.80	101.60
139.70	10.54	IEU	SS105 / HL110SS / HL120S / HL125S	HLIST®54	171.45	98.43
139.70	10.54	IEU	SS105 / HL110SS / HL120S / HL125S	HLIST®57	177.80	101.60
149.23	9.17	IEU	SS75	5-1/2FH	177.80	101.60
149.23	9.17	IEU	SS95 / SS105 / HL110SS	5-1/2FH	184.15	88.90
149.23	9.17	IEU	HL120S / HL125S	HLIDS®5-1/2FH	177.80	101.60
149.23	9.17	IEU	HL120S / HL125S	HLMT®5-1/2FH	177.80	101.60
149.23	9.17	IEU	HL120S / HL125S	HLST®57	177.80	107.95

Pipe Body OD (mm)	Nominal Wall Thickness (mm)	Upset Type	Grade	RSC Type	Tool Joint	
					OD (mm)	ID (mm)
149.23	9.17	IEU	HL120S / HL125S	HLIST®57	177.80	107.95
149.23	10.54	IEU	SS75	5-1/2FH	177.80	82.55
149.23	10.54	IEU	SS95 / SS105 / HL110SS	5-1/2FH	184.15	88.90
149.23	10.54	IEU	HL120S / HL125S	HLIDS®5-1/2FH	184.15	98.43
149.23	10.54	IEU	HL120S / HL125S	HLMT®5-1/2FH	184.15	98.43
149.23	10.54	IEU	HL120S / HL125S	HLST®57	184.15	101.60
149.23	10.54	IEU	HL120S / HL125S	HLIST®57	184.15	101.60
168.28	8.38	IEU	SS75 / SS95	6-5/8FH	203.20	127.00
168.28	8.38	IEU	SS105 / HL110SS	6-5/8FH	209.55	120.65
168.28	8.38	IEU	SS105 / HL110SS / HL120S / HL125S	HLIDS®6-5/8FH	203.20	127.00
168.28	9.19	IEU	SS75	6-5/8FH	203.20	127.00
168.28	9.19	IEU	SS95 / SS105 / HL110SS	6-5/8FH	209.55	120.65
168.28	9.19	IEU	SS105 / HL110SS / HL120S / HL125S	HLIDS®6-5/8FH	203.20	127.00

Note: Abbreviated steel grade

SS75 - HLDT-SS®75; SS95 - HLDT-SS®95; SS105 - HLDT-SS®105; HL110SS - HLDT-SS®110; HL120S - HLDT-S®120; HL125S - HLDT-S®125.

Table A.3 Commonly-used Heavy Weight Drill Pipes Data

Size	Pipe Body OD	Pipe Body ID	Central Upset OD	Elevator Upset OD	RSC Type	RSC Bevel Dia.	Tool Joint OD	Tool Joint ID	Drift Size
mm	mm	mm	mm	mm		mm	mm	mm	mm
88.9	88.9	57.15	101.6	98.4	NC38	116.3	120.7	57.15	50.80
88.9	88.9	52.39	101.6	98.4	NC38	116.3	127.0	52.39	46.04
88.9	88.9	50.80	101.6	92.4	HLIDS®31	100.4	104.8	50.80	44.45
88.9	88.9	52.39	101.6	92.4	HLST®31	99.2	104.8	52.39	46.04
88.9	88.9	57.15	101.6	98.4	HLIDS®38	116.3	120.7	57.15	50.80
88.9	88.9	57.15	101.6	98.4	HLMT®38	116.3	120.7	57.15	50.80
101.6	101.6	65.09	114.3	106.4	NC40	127.4	133.4	65.09	58.74
101.6	101.6	65.09	114.3	106.4	HLIDS®40	127.4	133.4	65.09	58.74
101.6	101.6	65.09	114.3	106.4	HLMT®40	123.8	133.4	65.09	58.74
101.6	101.6	65.09	114.3	106.4	HLST®39	121.2	123.8	65.09	58.74
101.6	101.6	65.09	114.3	106.4	HLIST®39	121.6	123.8	65.09	58.74
114.3	114.3	68.26	127.0	119.1	NC46	145.3	158.8	68.26	61.91
114.3	114.3	68.26	127.0	119.1	HLIDS®40	127.4	133.4	68.26	61.91
114.3	114.3	68.26	127.0	119.1	HLST®40	128.6	133.4	68.26	61.91
127.0	127.0	76.20	139.7	130.2	NC50	154.0	168.3	76.20	69.85
127.0	127.0	76.20	139.7	130.2	HLIDS®50	154.0	168.3	76.20	69.85
139.7	139.7	101.60	152.4	144.5	5-1/2FH	170.7	177.8	101.60	95.25
139.7	139.7	82.55	152.4	144.5	5-1/2FH	170.7	177.8	82.55	76.20
139.7	139.7	82.55	152.4	144.5	HLIST®50	160.5	165.1	82.55	76.20
139.7	139.7	82.55	152.4	144.5	HLIDS®5-1/2FH	170.7	177.8	82.55	76.20
139.7	139.7	101.60	152.4	144.5	HLST®54	164.4	171.5	101.60	95.25
139.7	139.7	101.60	152.4	144.5	HLIST®54	164.3	168.3	101.60	95.25
149.2	149.2	101.60	161.9	152.4	HLIDS®5-1/2FH	170.7	184.2	101.60	95.25
149.2	149.2	104.78	161.9	152.4	HLST®57	171.8	177.8	104.78	98.43
149.2	149.2	107.95	161.9	152.4	HLIST®57	170.7	177.8	107.95	101.60
168.3	168.3	114.30	181.0	176.2	6-5/8FH	195.7	209.6	114.30	107.95
168.3	168.3	127.00	181.0	176.2	6-5/8FH	195.7	203.2	127.00	120.65
168.3	168.3	127.00	181.0	176.2	HLIDS®6-5/8	195.7	203.2	127.00	120.65

Table A.4 Commonly-used Drill Collars Data

Size	OD	Bore	RSC Type	Length	RSC Bevel Dia.	Reference Bending Strength Ratio	Drift
	D	d		L	Df	BSR	
in	mm	mm		m	mm		mm
3 1/8	79.4	31.8	NC23	9.14	76.2	2.57	35.0
3 1/2	88.9	38.1	NC26	9.14	82.9	2.42	41.3
4 1/8	104.8	50.8	NC31	9.14 or 9.45	100.4	2.43	54.0
4 3/4	120.6	50.8	NC35	9.14 or 9.45	114.7	2.58	54.0
5	127.0	57.2	NC38	9.14 or 9.45	121.0	2.38	60.4
6	152.4	57.2	NC44	9.14 or 9.45	144.5	2.49	60.4
6	152.4	71.4	NC44	9.14 or 9.45	144.5	2.84	74.6
6 1/4	158.8	57.2	NC44	9.14 or 9.45	149.2	2.91	60.4
6 1/4	158.8	71.4	NC46	9.14 or 9.45	150.0	2.63	74.6
6 1/2	165.1	57.2	NC46	9.14 or 9.45	154.8	2.76	60.4
6 1/2	165.1	71.4	NC46	9.14 or 9.45	154.8	3.05	74.6
6 3/4	171.4	57.2	NC46	9.14 or 9.45	159.5	3.18	60.4
7	177.8	57.2	NC50	9.14 or 9.45	164.7	2.54	60.4
7	177.8	71.4	NC50	9.14 or 9.45	164.7	2.73	74.6
7 1/4	184.2	71.4	NC50	9.14 or 9.45	169.5	3.12	74.6
7 3/4	196.8	71.4	NC56	9.14 or 9.45	185.3	2.70	74.6
8	203.2	71.4	NC56	9.14 or 9.45	190.1	3.02	74.6
8 1/4	209.6	71.4	6-5/8REG	9.14 or 9.45	195.6	2.93	74.6
9	228.6	71.4	NC61	9.14 or 9.45	212.7	3.17	74.6
9 1/2	241.3	76.2	7-5/8REG	9.14 or 9.45	223.8	2.81	79.4
9 3/4	247.6	76.2	NC70	9.14 or 9.45	232.6	2.57	79.4
10	254.0	76.2	NC70	9.14 or 9.45	237.3	2.81	79.4
11	279.4	76.2	8-5/8REG	9.14 or 9.45	266.7	2.84	79.4

Table A.5 HLIDS® Connection Mechanical Characteristics

RSC Type	Tool Joint OD (mm)	Tool Joint ID (mm)	Torsional Strength (N·m)	Tensile Strength (kN)	Recommended Makeup Torque (N·m)
HLIDS®23	76.20	34.93	8800	1300	5300
HLIDS®26	85.73	44.45	12100	1400	7300
HLIDS®31	111.13	41.28	32600	2800	19500
	104.78	53.98	20700	2000	12400
	104.78	50.80	23900	2200	14400
HLIDS®38	127.00	65.09	36100	2900	21600
	127.00	61.91	40600	3200	24400
	127.00	53.98	50900	3800	30500
	120.65	68.26	30900	2600	18500
	120.65	65.09	34500	2900	20700
HLIDS®40	139.70	50.80	70300	4800	42200
	133.35	71.44	40000	3200	24000
	133.35	68.26	45300	3500	27200
	133.35	65.09	50400	3700	30200
HLIDS®46	133.35	61.91	54600	4000	32800
	152.40	82.55	59700	4000	35800
	152.40	76.20	73300	4700	44000
HLIDS®50	152.40	69.85	85700	5300	51400
	168.28	95.25	66200	4200	39700
	168.28	88.90	83500	4900	50100
	168.28	82.55	99500	5700	59700
	168.28	76.20	114000	6300	68400
	168.28	69.85	127300	6900	76400
HLIDS®5-1/2FH	165.10	95.25	65900	4200	39600
	190.50	82.55	158700	7900	95200
	190.50	76.20	174400	8600	104700
	184.15	95.25	121800	6500	73100
	184.15	92.08	131300	6800	78800
	184.15	88.90	140500	7200	84300
HLIDS®6-5/8FH	177.80	101.60	100900	5600	60500
	177.80	98.43	111100	6100	66700
	209.55	120.65	162300	7500	97400
	209.55	117.48	176500	8000	105900
HLIDS®6-5/8FH	203.20	127.00	131800	6500	79100
	203.20	123.83	146800	7000	88100

Note: All data is calculated based on SMYS 827MPa, and Makeup Torques are based on a friction factor of 1.0.

Table A.6 HLMT® Connection Mechanical Characteristics

RSC Type	Tool Joint OD (mm)	Tool Joint ID (mm)	Torsional Strength (N·m)	Tensile Strength (kN)	Recommended Makeup Torque (N·m)
HLMT®2-3/8PAC	73.03	34.93	9500	1100	5700
HLMT®2-7/8PAC	79.38	38.10	11600	1200	7000
HLMT®38	127.00	65.09	40100	2900	24100
	127.00	61.91	44700	3200	26800
	127.00	57.15	51100	3500	30700
	123.83	61.91	44500	3200	26700
	120.65	68.26	34900	2600	20900
	120.65	65.09	38500	2900	23100
HLMT®40	139.70	61.91	59400	4000	35700
	133.35	68.26	49000	3500	29400
	133.35	65.09	54100	3700	32500
	133.35	61.91	58400	4000	35000
HLMT®46	152.40	82.55	64000	4000	38400
	152.40	76.20	77700	4700	46600
HLMT®50	168.28	88.90	89700	4900	53800
	168.28	82.55	105700	5700	63400
	168.28	76.20	120400	6300	72200
	165.10	88.90	89400	4900	53600
HLMT®5-1/2FH	177.80	101.60	104700	5600	62800
HLMT®5-1/2FH	177.80	98.43	115000	6100	69000

Note: All data is calculated based on SMYS 827MPa, and Makeup Torques are based on a friction factor of 1.0.

Table A.7 HLST® Connection Mechanical Characteristics

RSC Type	Tool Joint OD (mm)	Tool Joint ID (mm)	Torsional Strength (N·m)	Tensile Strength (kN)	Recommended Makeup Torque (N·m)
HLST®26	85.73	44.45	15000	1300	9000
HLST®31	104.78	53.98	25800	1900	15500
	104.78	50.80	29100	2100	17500
	101.60	57.15	22100	1700	13300
HLST®36	120.65	65.09	33100	2200	19900
	120.65	61.91	37700	2500	22600
	120.65	57.15	44000	2900	26400
	120.65	53.98	47900	3100	28700
HLST®39	127.00	65.09	52700	3200	31600
	127.00	61.91	56800	3500	34100
	123.83	71.44	42100	2700	25300
	123.83	68.26	47000	2900	28200
	123.83	65.09	49200	3200	29500
HLST®40	136.53	65.09	67600	3900	40500
	133.35	68.26	62100	3600	37200
	133.35	65.09	66400	3900	39800
HLST®46	158.75	76.20	95000	4900	57000
	158.75	69.85	107900	5500	64700
	152.40	88.90	64800	3500	38900
	152.40	82.55	80200	4200	48100
	152.40	76.20	94400	4900	56600
HLST®52	168.28	101.60	84500	4100	50700
	168.28	95.25	104200	4900	62500
	168.28	88.90	122400	5700	73400
	165.10	104.78	73900	3700	44300
HLST®54	174.63	95.25	134000	5900	80400
	171.45	104.78	102600	4700	61600
	171.45	101.60	113300	5100	68000
	168.28	107.95	91200	4300	54700
HLST®57	180.98	101.60	148900	6400	89300
	177.80	107.95	125900	5500	75500
	177.80	101.60	139700	6400	83800

Note: All data is calculated based on SMYS 827MPa, and Makeup Torques are based on a friction factor of 1.0.

Table A.8 HLIST® Connection Mechanical Characteristics

RSC Type	Tool Joint OD (mm)	Tool Joint ID (mm)	Torsional Strength (N·m)	Tensile Strength (kN)	Recommended Makeup Torque (N·m)
HLIST®38	123.83	61.91	47300	2900	28400
	120.65	68.26	37600	2400	22500
	120.65	65.09	42500	2700	25500
	120.65	61.91	47100	2900	28300
HLIST®39	127.00	65.09	55300	3200	33200
	123.83	68.26	48700	3000	29200
	123.83	65.09	51000	3200	30600
HLIST®46	158.75	82.55	95200	4800	57100
	152.40	88.90	78800	4100	47300
	152.40	82.55	89100	4800	53500
HLIST®50	168.28	88.90	123300	5600	74000
	168.28	85.73	131800	6000	79100
	165.10	95.25	104800	4800	62900
	165.10	92.08	114000	5200	68400
HLIST®54	171.45	101.60	117400	5100	70500
	171.45	98.43	127800	5600	76700
	168.28	107.95	95200	4300	57100
	168.28	101.60	114300	5100	68600
HLIST®57	177.80	107.95	128300	5400	77000
	177.80	101.60	146100	6200	87600

Note: All data is calculated based on SMYS 827MPa, and Makeup Torques are based on a friction factor of 1.0.

Appendix B

Tables in USC units

Table B.1 Commonly-used Drill Pipes Data

Pipe Body OD (in)	Nominal Weight (lb/ft)	Upset Type	Grade	RSC Type	Tool Joint	
					OD (in)	ID (in)
2 3/8	6.65	EU	E / X / G	NC26	3 3/8	1 3/4
2 3/8	6.65	EU	G / S / Z / V	HLIDS®26	3 3/8	1 3/4
2 3/8	6.65	EU	S / Z / V	HLST®26	3 3/8	1 3/4
2 3/8	6.65	IU	G / S	HLIDS®23	3	1 3/8
2 3/8	6.65	IU	G / S	HLMT®2-3/8PAC	2 7/8	1 3/8
2 7/8	10.40	EU	E	NC31	4 1/8	2 1/8
2 7/8	10.40	EU	X / G	NC31	4 1/8	2
2 7/8	10.40	EU	S	NC31	4 3/8	1 5/8
2 7/8	10.40	EU	G / S / Z / V	HLIDS®31	4 1/8	2
2 7/8	10.40	EU	G / S / Z / V	HLST®31	4 1/8	2
2 7/8	10.40	IU	E / X / G	HLIDS®26	3 3/8	1 3/4
2 7/8	10.40	IU	E / X / G	HLMT®2-7/8PAC	3 1/8	1 1/2
2 7/8	10.40	IU	E / X / G	HLST®26	3 3/8	1 3/4
3 1/2	13.30	EU	E	NC38	4 3/4	2 11/16
3 1/2	13.30	EU	X	NC38	5	2 9/16
3 1/2	13.30	EU	G	NC38	5	2 7/16
3 1/2	13.30	EU	S	NC38	5	2 1/8
3 1/2	13.30	EU	G	HLIDS®38	5	2 9/16
3 1/2	13.30	EU	S / Z	HLIDS®38	5	2 7/16
3 1/2	13.30	EU	V	HLIDS®38	5	2 1/8
3 1/2	13.30	EU	G	HLMT®38	4 3/4	2 11/16
3 1/2	13.30	EU	S / Z / V	HLMT®38	4 3/4	2 9/16
3 1/2	13.30	EU	G	HLST®36	4 3/4	2 7/16
3 1/2	13.30	EU	S / Z / V	HLST®36	4 3/4	2 1/8
3 1/2	13.30	EU	G	HLST®39	4 7/8	2 13/16
3 1/2	13.30	EU	S	HLST®39	4 7/8	2 11/16
3 1/2	13.30	EU	Z / V	HLST®39	5	2 9/16
3 1/2	13.30	EU	G	HLIST®38	4 3/4	2 11/16
3 1/2	13.30	EU	S / Z / V	HLIST®38	4 3/4	2 9/16
3 1/2	13.30	EU	G / S / Z / V	HLIST®39	4 7/8	2 11/16
3 1/2	13.30	IU	E / X / G	HLIDS®31	4 1/8	2

Pipe Body OD (in)	Nominal Weight (lb/ft)	Upset Type	Grade	RSC Type	Tool Joint	
					OD (in)	ID (in)
3 1/2	13.30	IU	S	HLIDS®31	4 1/4	2
3 1/2	13.30	IU	E	HLST®31	4	2 1/4
3 1/2	13.30	IU	X / G / S	HLST®31	4 1/8	2
3 1/2	15.50	EU	E	NC38	5	2 9/16
3 1/2	15.50	EU	X	NC38	5	2 7/16
3 1/2	15.50	EU	G	NC38	5	2 1/8
3 1/2	15.50	EU	S	NC40	5 1/2	2 1/4
3 1/2	15.50	EU	E / X	HLIDS®38	5	2 9/16
3 1/2	15.50	EU	G	HLIDS®38	5	2 7/16
3 1/2	15.50	EU	S / Z / V	HLIDS®38	5	2 1/8
3 1/2	15.50	EU	G	HLMT®38	4 3/4	2 9/16
3 1/2	15.50	EU	S / Z	HLMT®38	4 7/8	2 7/16
3 1/2	15.50	EU	V	HLMT®38	5	2 1/4
3 1/2	15.50	EU	X	HLST®36	4 3/4	2 9/16
3 1/2	15.50	EU	G	HLST®36	4 3/4	2 7/16
3 1/2	15.50	EU	S / Z / V	HLST®36	4 3/4	2 1/8
3 1/2	15.50	EU	G / S	HLST®39	5	2 9/16
3 1/2	15.50	EU	Z / V	HLST®39	5	2 7/16
3 1/2	15.50	EU	G	HLIST®38	4 3/4	2 9/16
3 1/2	15.50	EU	S / Z / V	HLIST®38	4 3/4	2 7/16
3 1/2	15.50	EU	G / S / Z / V	HLIST®39	4 7/8	2 9/16
4	14.00	IU	E	NC40	5 1/4	2 13/16
4	14.00	IU	X	NC40	5 1/4	2 11/16
4	14.00	IU	G	NC40	5 1/2	2 7/16
4	14.00	IU	S	NC40	5 1/2	2
4	14.00	IU	E / X	HLIDS®38	5	2 11/16
4	14.00	IU	G	HLIDS®38	5	2 9/16
4	14.00	IU	S	HLIDS®38	5	2 7/16
4	14.00	IU	E / X	HLIDS®40	5 1/4	2 13/16
4	14.00	IU	G	HLIDS®40	5 1/4	2 11/16
4	14.00	IU	S / Z / V	HLIDS®40	5 1/4	2 9/16
4	14.00	IU	G	HLMT®38	5	2 9/16
4	14.00	IU	S	HLMT®38	5	2 7/16
4	14.00	IU	G	HLMT®40	5 1/4	2 11/16
4	14.00	IU	S / Z / V	HLMT®40	5 1/4	2 9/16
4	14.00	IU	E / X	HLST®36	4 3/4	2 9/16

Pipe Body OD (in)	Nominal Weight (lb/ft)	Upset Type	Grade	RSC Type	Tool Joint	
					OD (in)	ID (in)
4	14.00	IU	G	HLST®36	4 3/4	2 7/16
4	14.00	IU	S	HLST®36	4 3/4	2 1/8
4	14.00	IU	E / X	HLST®39	4 7/8	2 13/16
4	14.00	IU	G	HLST®39	4 7/8	2 11/16
4	14.00	IU	S	HLST®39	4 7/8	2 9/16
4	14.00	IU	Z / V	HLST®39	5	2 9/16
4	14.00	IU	G	HLIST®38	4 3/4	2 9/16
4	14.00	IU	S	HLIST®38	4 3/4	2 7/16
4	14.00	IU	G	HLIST®39	4 7/8	2 11/16
4	14.00	IU	S / Z / V	HLIST®39	4 7/8	2 9/16
4	15.70	IU	E / X	HLIDS®40	5 1/4	2 13/16
4	15.70	IU	G	HLIDS®40	5 1/4	2 11/16
4	15.70	IU	S	HLIDS®40	5 1/4	2 9/16
4	15.70	IU	Z / V	HLIDS®40	5 1/2	2 7/16
4	15.70	IU	G	HLMT®40	5 1/4	2 11/16
4	15.70	IU	S / Z	HLMT®40	5 1/4	2 9/16
4	15.70	IU	V	HLMT®40	5 1/4	2 7/16
4	15.70	IU	G	HLST®39	4 7/8	2 9/16
4	15.70	IU	S / Z / V	HLST®39	5	2 7/16
4	15.70	IU	G / S	HLST®40	5 1/4	2 11/16
4	15.70	IU	Z / V	HLST®40	5 3/8	2 9/16
4	15.70	IU	G	HLIST®39	4 7/8	2 9/16
4	15.70	IU	S / Z / V	HLIST®39	5	2 7/16
4 1/2	16.60	IEU	E	NC46	6 1/4	3 1/4
4 1/2	16.60	IEU	X / G	NC46	6 1/4	3
4 1/2	16.60	IEU	S	NC46	6 1/4	2 3/4
4 1/2	16.60	IEU	E / X / G	HLIDS®46	6	3 1/4
4 1/2	16.60	IEU	S / Z / V	HLIDS®46	6	3
4 1/2	16.60	IEU	G / S / Z / V	HLMT®46	6	3 1/4
4 1/2	16.60	IEU	G / S / Z / V	HLST®46	6	3 1/4
4 1/2	16.60	IEU	G / S / Z / V	HLIST®46	6	3 1/4
4 1/2	16.60	IEU	G	HLIDS®40	5 1/4	2 11/16
4 1/2	16.60	IEU	S	HLIDS®40	5 1/4	2 9/16
4 1/2	16.60	IEU	G / S	HLST®40	5 1/4	2 11/16
4 1/2	20.00	IEU	E	NC46	6 1/4	3
4 1/2	20.00	IEU	X	NC46	6 1/4	2 3/4

Pipe Body OD (in)	Nominal Weight (lb/ft)	Upset Type	Grade	RSC Type	Tool Joint	
					OD (in)	ID (in)
4 1/2	20.00	IEU	G	NC46	6 1/4	2 1/2
4 1/2	20.00	IEU	S	NC46	6 1/4	2 1/4
4 1/2	20.00	IEU	E / X / G	HLIDS®46	6	3
4 1/2	20.00	IEU	S / Z / V	HLIDS®46	6	2 3/4
4 1/2	20.00	IEU	G / S / Z / V	HLMT®46	6	3
4 1/2	20.00	IEU	G / S / Z / V	HLST®46	6	3
4 1/2	20.00	IEU	G / S / Z / V	HLIST®46	6	3
5	19.50	IEU	E	NC50	6 5/8	3 3/4
5	19.50	IEU	X	NC50	6 5/8	3 1/2
5	19.50	IEU	G	NC50	6 5/8	3 1/4
5	19.50	IEU	S	NC50	6 5/8	2 3/4
5	19.50	IEU	E	HLIDS®50	6 1/2	3 3/4
5	19.50	IEU	X	HLIDS®50	6 5/8	3 3/4
5	19.50	IEU	G	HLIDS®50	6 5/8	3 1/2
5	19.50	IEU	S / Z / V	HLIDS®50	6 5/8	3 1/4
5	19.50	IEU	G / S / Z / V	HLMT®50	6 5/8	3 1/2
5	19.50	IEU	E / X	HLST®46	6	3 1/2
5	19.50	IEU	G	HLST®46	6	3 1/4
5	19.50	IEU	S / Z / V	HLST®46	6	3
5	19.50	IEU	E / X / G	HLST®52	6 1/2	4
5	19.50	IEU	S / Z / V	HLST®52	6 1/2	3 3/4
5	19.50	IEU	G / S / Z	HLIST®46	6	3 1/2
5	19.50	IEU	S / Z / V	HLIST®46	6 1/4	3 1/4
5	19.50	IEU	G	HLIST®50	6 1/2	4
5	19.50	IEU	S / Z / V	HLIST®50	6 1/2	3 3/4
5	25.60	IEU	E	NC50	6 5/8	3 1/2
5	25.60	IEU	X	NC50	6 5/8	3
5	25.60	IEU	G	NC50	6 5/8	2 3/4
5	25.60	IEU	S	5-1/2FH	7 1/4	3 1/4
5	25.60	IEU	E	HLIDS®50	6 1/2	3 3/4
5	25.60	IEU	X / G	HLIDS®50	6 5/8	3 1/2
5	25.60	IEU	S / Z / V	HLIDS®50	6 5/8	3
5	25.60	IEU	G	HLMT®50	6 5/8	3 1/2
5	25.60	IEU	S / Z / V	HLMT®50	6 5/8	3
5	25.60	IEU	E	HLST®46	6	3 1/2
5	25.60	IEU	X	HLST®46	6	3 1/4

Pipe Body OD (in)	Nominal Weight (lb/ft)	Upset Type	Grade	RSC Type	Tool Joint	
					OD (in)	ID (in)
5	25.60	IEU	G	HLST®46	6 1/4	3
5	25.60	IEU	S	HLST®46	6 1/4	2 3/4
5	25.60	IEU	E / X / G	HLST®52	6 5/8	3 3/4
5	25.60	IEU	S / Z / V	HLST®52	6 5/8	3 1/4
5	25.60	IEU	G	HLIST®50	6 5/8	3 3/4
5	25.60	IEU	S / Z / V	HLIST®50	6 5/8	3 1/4
5 1/2	21.90	IEU	E	5-1/2FH	7	4
5 1/2	21.90	IEU	X	5-1/2FH	7	3 3/4
5 1/2	21.90	IEU	G	5-1/2FH	7 1/4	3 1/2
5 1/2	21.90	IEU	S	5-1/2FH	7 1/2	3
5 1/2	21.90	IEU	E / X / G / S / Z / V / U	HLIDS®5-1/2FH	7	4
5 1/2	21.90	IEU	G / S / Z / V / U	HLMT®5-1/2FH	7	4
5 1/2	21.90	IEU	E / X / G	HLST®52	6 1/2	4
5 1/2	21.90	IEU	S	HLST®52	6 5/8	3 3/4
5 1/2	21.90	IEU	E / X / G	HLST®54	6 5/8	4 1/4
5 1/2	21.90	IEU	S	HLST®54	6 3/4	4
5 1/2	21.90	IEU	Z / V	HLST®54	6 7/8	3 7/8
5 1/2	21.90	IEU	G / S / Z / V / U	HLST®57	7	4 1/4
5 1/2	21.90	IEU	G	HLIST®54	6 5/8	4 1/4
5 1/2	21.90	IEU	S / Z / V	HLIST®54	6 3/4	4
5 1/2	21.90	IEU	G / S / Z / V / U	HLIST®57	7	4 1/4
5 1/2	24.70	IEU	E	5-1/2FH	7	4
5 1/2	24.70	IEU	X / G	5-1/2FH	7 1/4	3 1/2
5 1/2	24.70	IEU	S	5-1/2FH	7 1/2	3
5 1/2	24.70	IEU	E / X / G	HLIDS®5-1/2FH	7	4
5 1/2	24.70	IEU	S / Z / V / U	HLIDS®5-1/2FH	7 1/4	3 3/4
5 1/2	24.70	IEU	G / S	HLMT®5-1/2FH	7	4
5 1/2	24.70	IEU	Z / V / U	HLMT®5-1/2FH	7 1/4	3 3/4
5 1/2	24.70	IEU	G	HLST®54	6 3/4	4
5 1/2	24.70	IEU	S / Z / V	HLST®54	6 7/8	3 3/4
5 1/2	24.70	IEU	G / S / Z / V / U	HLST®57	7 1/8	4
5 1/2	24.70	IEU	G	HLIST®54	6 3/4	4
5 1/2	24.70	IEU	S / Z / V	HLIST®54	6 7/8	3 3/4
5 1/2	24.70	IEU	G / S / Z / V / U	HLIST®57	7 1/8	4
5 7/8	23.40	IEU	S / Z / V / U	HLIDS®5-1/2FH	7 1/4	4
5 7/8	23.40	IEU	S / Z / V / U	HLMT®5-1/2FH	7 1/4	4

Pipe Body OD (in)	Nominal Weight (lb/ft)	Upset Type	Grade	RSC Type	Tool Joint	
					OD (in)	ID (in)
5 7/8	23.40	IEU	S / Z / V / U	HLST®57	7	4 1/8
5 7/8	23.40	IEU	S / Z / V / U	HLIST®57	7	4 1/8
5 7/8	26.30	IEU	S / Z / V / U	HLIDS®5-1/2FH	7 1/4	3 7/8
5 7/8	26.30	IEU	S / Z / V / U	HLMT®5-1/2FH	7 1/4	3 7/8
5 7/8	26.30	IEU	S / Z / V / U	HLST®57	7 1/4	4
5 7/8	26.30	IEU	S / Z / V / U	HLIST®57	7 1/4	4
6 5/8	25.20	IEU	E / X	6-5/8FH	8	5
6 5/8	25.20	IEU	G	6-5/8FH	8 1/4	4 3/4
6 5/8	25.20	IEU	S	6-5/8FH	8 1/4	4 1/4
6 5/8	25.20	IEU	E / X / G / S / Z / V / U	HLIDS®6-5/8FH	8	5
6 5/8	27.70	IEU	E	6-5/8FH	8	5
6 5/8	27.70	IEU	X / G	6-5/8FH	8 1/4	4 3/4
6 5/8	27.70	IEU	S	6-5/8FH	8 1/2	4 1/4
6 5/8	27.70	IEU	E / X / G	HLIDS®6-5/8FH	8	5
6 5/8	27.70	IEU	S / Z / V / U	HLIDS®6-5/8FH	8 1/4	4 3/4

Notes:

Abbreviated steel grade: E - E75; X - X95; G - G105; S - S135; Z - HLDT-SH®Z140; V - HLDT-SH®V150; U - HLDT-SH®U165.

The tool joint OD and ID listed above are the dimensions commonly used in drilling. It can be customized according to the actual well conditions and user requirements.

Table B.2 Commonly-used Sour Service Drill Pipes Data

Pipe Body OD (in)	Nominal Weight (lb/ft)	Upset Type	Grade	RSC Type	Tool Joint	
					OD (in)	ID (in)
2 3/8	6.65	EU	SS75 / SS95 / SS105 / HL110SS	NC26	3 3/8	1 3/4
2 3/8	6.65	EU	SS75 / SS95 / SS105 / HL110SS / HL120S	HLIDS®26	3 3/8	1 3/4
2 3/8	6.65	EU	SS105 / HL110SS / HL120S	HLST®26	3 3/8	1 3/4
2 3/8	6.65	IU	SS105 / HL110SS / HL120S	HLIDS®23	3	1 3/8
2 3/8	6.65	IU	SS105 / HL110SS / HL120S	HLMT®2-3/8PAC	2 7/8	1 3/8
2 7/8	10.40	EU	SS75	NC31	4 1/8	2 1/8
2 7/8	10.40	EU	SS95 / SS105 / HL110SS	NC31	4 1/8	2
2 7/8	10.40	EU	SS105 / HL110SS / HL120S	HLIDS®31	4 1/8	2
2 7/8	10.40	EU	SS105 / HL110SS / HL120S	HLST®31	4 1/8	2
2 7/8	10.40	IU	SS75 / SS95 / SS105 / HL110SS	HLIDS®26	3 3/8	1 3/4
2 7/8	10.40	IU	SS75 / SS95 / SS105 / HL110SS	HLMT®2-7/8PAC	3 1/8	1 1/2
2 7/8	10.40	IU	SS75 / SS95 / SS105 / HL110SS	HLST®26	3 3/8	1 3/4
3 1/2	13.30	EU	SS75	NC38	4 3/4	2 11/16
3 1/2	13.30	EU	SS95	NC38	5	2 9/16
3 1/2	13.30	EU	SS105 / HL110SS	NC38	5	2 7/16
3 1/2	13.30	EU	SS105 / HL110SS / HL120S	HLIDS®38	5	2 9/16
3 1/2	13.30	EU	SS105 / HL110SS / HL120S	HLMT®38	4 7/8	2 9/16
3 1/2	13.30	EU	SS105 / HL110SS / HL120S	HLST®36	4 3/4	2 1/4
3 1/2	13.30	EU	SS105 / HL110SS / HL120S	HLST®39	4 7/8	2 11/16
3 1/2	13.30	EU	SS105 / HL110SS / HL120S	HLIST®38	4 3/4	2 9/16
3 1/2	13.30	EU	SS105 / HL110SS / HL120S	HLIST®39	4 7/8	2 11/16
3 1/2	13.30	IU	SS75 / SS95 / SS105 / HL110SS	HLIDS®31	4 1/8	2
3 1/2	13.30	IU	SS75 / SS95 / SS105 / HL110SS	HLST®31	4 1/8	2
3 1/2	15.50	EU	SS75	NC38	5	2 9/16
3 1/2	15.50	EU	SS95	NC38	5	2 7/16
3 1/2	15.50	EU	SS105 / HL110SS	NC38	5	2 1/8
3 1/2	15.50	EU	SS105 / HL110SS / HL120S	HLIDS®38	5	2 7/16
3 1/2	15.50	EU	SS105 / HL110SS / HL120S	HLMT®38	4 7/8	2 7/16
3 1/2	15.50	EU	SS105 / HL110SS / HL120S	HLST®36	4 3/4	2 1/8
3 1/2	15.50	EU	SS105 / HL110SS / HL120S	HLST®39	5	2 9/16
3 1/2	15.50	EU	SS105 / HL110SS / HL120S	HLIST®38	4 3/4	2 7/16
3 1/2	15.50	EU	SS105 / HL110SS / HL120S	HLIST®39	4 7/8	2 9/16
4	14.00	IU	SS75	NC40	5 1/4	2 13/16
4	14.00	IU	SS95	NC40	5 1/4	2 11/16

Pipe Body OD (in)	Nominal Weight (lb/ft)	Upset Type	Grade	RSC Type	Tool Joint	
					OD (in)	ID (in)
4	14.00	IU	SS105 / HL110SS	NC40	5 1/2	2 7/16
4	14.00	IU	SS105 / HL110SS / HL120S / HL125S	HLIDS®38	5	2 9/16
4	14.00	IU	SS105 / HL110SS / HL120S / HL125S	HLIDS®40	5 1/4	2 11/16
4	14.00	IU	SS105 / HL110SS / HL120S / HL125S	HLMT®38	5	2 9/16
4	14.00	IU	SS105 / HL110SS / HL120S / HL125S	HLMT®40	5 1/4	2 11/16
4	14.00	IU	SS105 / HL110SS / HL120S / HL125S	HLST®36	4 3/4	2 1/8
4	14.00	IU	SS105 / HL110SS / HL120S / HL125S	HLST®39	4 7/8	2 9/16
4	14.00	IU	SS105 / HL110SS / HL120S / HL125S	HLIST®38	4 3/4	2 7/16
4	14.00	IU	SS105 / HL110SS / HL120S / HL125S	HLIST®39	4 7/8	2 9/16
4	15.70	IU	SS105 / HL110SS / HL120S / HL125S	HLIDS®40	5 1/4	2 9/16
4	15.70	IU	SS105 / HL110SS / HL120S / HL125S	HLMT®40	5 1/4	2 9/16
4	15.70	IU	SS105 / HL110SS / HL120S / HL125S	HLST®39	4 7/8	2 9/16
4	15.70	IU	SS105 / HL110SS / HL120S / HL125S	HLST®40	5 1/4	2 11/16
4	15.70	IU	SS105 / HL110SS / HL120S / HL125S	HLIST®39	4 7/8	2 9/16
4 1/2	16.60	IEU	SS75	NC46	6 1/4	3 1/4
4 1/2	16.60	IEU	SS95 / SS105 / HL110SS	NC46	6 1/4	3
4 1/2	16.60	IEU	HL120S / HL125S	NC46	6 1/4	2 3/4
4 1/2	16.60	IEU	SS105 / HL110SS / HL120S / HL125S	HLIDS®46	6	3 1/4
4 1/2	16.60	IEU	SS105 / HL110SS / HL120S / HL125S	HLMT®46	6	3 1/4
4 1/2	16.60	IEU	SS105 / HL110SS / HL120S / HL125S	HLST®46	6	3 1/4
4 1/2	16.60	IEU	SS105 / HL110SS / HL120S / HL125S	HLIST®46	6	3 1/4
4 1/2	16.60	IEU	SS105 / HL110SS / HL120S / HL125S	HLIDS®40	5 1/4	2 9/16
4 1/2	16.60	IEU	SS105 / HL110SS / HL120S / HL125S	HLST®40	5 1/4	2 11/16
4 1/2	20.00	IEU	SS75	NC46	6 1/4	3
4 1/2	20.00	IEU	SS95	NC46	6 1/4	2 3/4
4 1/2	20.00	IEU	SS105 / HL110SS	NC46	6 1/4	2 1/2
4 1/2	20.00	IEU	HL120S / HL125S	NC46	6 1/4	2 1/4
4 1/2	20.00	IEU	SS105 / HL110SS / HL120S / HL125S	HLIDS®46	6	3
4 1/2	20.00	IEU	SS105 / HL110SS / HL120S / HL125S	HLMT®46	6	3
4 1/2	20.00	IEU	SS105 / HL110SS / HL120S / HL125S	HLST®46	6	3
4 1/2	20.00	IEU	SS105 / HL110SS / HL120S / HL125S	HLIST®46	6	3
5	19.50	IEU	SS75	NC50	6 5/8	3 3/4
5	19.50	IEU	SS95	NC50	6 5/8	3 1/2
5	19.50	IEU	SS105 / HL110SS	NC50	6 5/8	3 1/4
5	19.50	IEU	SS105 / HL110SS / HL120S / HL125S	HLIDS®50	6 5/8	3 1/2
5	19.50	IEU	SS105 / HL110SS / HL120S / HL125S	HLMT®50	6 5/8	3 1/2

Pipe Body OD (in)	Nominal Weight (lb/ft)	Upset Type	Grade	RSC Type	Tool Joint	
					OD (in)	ID (in)
5	19.50	IEU	SS105 / HL110SS / HL120S / HL125S	HLST®46	6	3 1/4
5	19.50	IEU	SS75 / SS95 / SS105 / HL110SS	HLST®52	6 1/2	4
5	19.50	IEU	HL120S / HL125S	HLST®52	6 1/2	3 3/4
5	19.50	IEU	SS105 / HL110SS / HL120S / HL125S	HLIST®46	6	3 1/2
5	19.50	IEU	SS105 / HL110SS / HL120S / HL125S	HLIST®50	6 1/2	3 3/4
5	25.60	IEU	SS75	NC50	6 5/8	3 1/2
5	25.60	IEU	SS95	NC50	6 5/8	3
5	25.60	IEU	SS105 / HL110SS	NC50	6 5/8	2 3/4
5	25.60	IEU	SS105 / HL110SS / HL120S / HL125S	HLIDS®50	6 5/8	3
5	25.60	IEU	SS105 / HL110SS / HL120S / HL125S	HLMT®50	6 5/8	3
5	25.60	IEU	SS105 / HL110SS / HL120S / HL125S	HLST®46	6 1/4	2 3/4
5	25.60	IEU	SS105 / HL110SS / HL120S / HL125S	HLST®52	6 5/8	3 3/8
5	25.60	IEU	SS105 / HL110SS / HL120S / HL125S	HLIST®50	6 5/8	3 1/2
5 1/2	21.90	IEU	SS75	5-1/2FH	7	4
5 1/2	21.90	IEU	SS95	5-1/2FH	7	3 3/4
5 1/2	21.90	IEU	SS105 / HL110SS	5-1/2FH	7 1/4	3 1/2
5 1/2	21.90	IEU	SS105 / HL110SS / HL120S / HL125S	HLIDS®5-1/2FH	7	4
5 1/2	21.90	IEU	SS105 / HL110SS / HL120S / HL125S	HLMT®5-1/2FH	7	4
5 1/2	21.90	IEU	SS105 / HL110SS / HL120S / HL125S	HLST®52	6 1/2	3 3/4
5 1/2	21.90	IEU	SS105 / HL110SS / HL120S / HL125S	HLST®54	6 3/4	4
5 1/2	21.90	IEU	SS105 / HL110SS / HL120S / HL125S	HLST®57	7	4 1/8
5 1/2	21.90	IEU	SS105 / HL110SS / HL120S / HL125S	HLIST®54	6 5/8	4
5 1/2	21.90	IEU	SS105 / HL110SS / HL120S / HL125S	HLIST®57	7	4 1/8
5 1/2	24.70	IEU	SS75	5-1/2FH	7	4
5 1/2	24.70	IEU	SS95 / SS105 / HL110SS	5-1/2FH	7 1/4	3 1/2
5 1/2	24.70	IEU	SS105 / HL110SS / HL120S / HL125S	HLIDS®5-1/2FH	7	4
5 1/2	24.70	IEU	SS105 / HL110SS / HL120S / HL125S	HLMT®5-1/2FH	7	4
5 1/2	24.70	IEU	SS105 / HL110SS / HL120S / HL125S	HLST®54	6 7/8	3 7/8
5 1/2	24.70	IEU	SS105 / HL110SS / HL120S / HL125S	HLST®57	7	4
5 1/2	24.70	IEU	SS105 / HL110SS / HL120S / HL125S	HLIST®54	6 3/4	3 7/8
5 1/2	24.70	IEU	SS105 / HL110SS / HL120S / HL125S	HLIST®57	7	4
5 7/8	23.40	IEU	SS75	5-1/2FH	7	4
5 7/8	23.40	IEU	SS95 / SS105 / HL110SS	5-1/2FH	7 1/4	3 1/2
5 7/8	23.40	IEU	HL120S / HL125S	HLIDS®5-1/2FH	7	4
5 7/8	23.40	IEU	HL120S / HL125S	HLMT®5-1/2FH	7	4
5 7/8	23.40	IEU	HL120S / HL125S	HLST®57	7	4 1/4

Pipe Body OD (in)	Nominal Weight (lb/ft)	Upset Type	Grade	RSC Type	Tool Joint	
					OD (in)	ID (in)
5 7/8	23.40	IEU	HL120S / HL125S	HLIST®57	7	4 1/4
5 7/8	26.30	IEU	SS75	5-1/2FH	7	3 1/4
5 7/8	26.30	IEU	SS95 / SS105 / HL110SS	5-1/2FH	7 1/4	3 1/2
5 7/8	26.30	IEU	HL120S / HL125S	HLIDS®5-1/2FH	7 1/4	3 7/8
5 7/8	26.30	IEU	HL120S / HL125S	HLMT®5-1/2FH	7 1/4	3 7/8
5 7/8	26.30	IEU	HL120S / HL125S	HLST®57	7 1/4	4
5 7/8	26.30	IEU	HL120S / HL125S	HLIST®57	7 1/4	4
6 5/8	25.20	IEU	SS75 / SS95	6-5/8FH	8	5
6 5/8	25.20	IEU	SS105 / HL110SS	6-5/8FH	8 1/4	4 3/4
6 5/8	25.20	IEU	SS105 / HL110SS / HL120S / HL125S	HLIDS®6-5/8FH	8	5
6 5/8	27.70	IEU	SS75	6-5/8FH	8	5
6 5/8	27.70	IEU	SS95 / SS105 / HL110SS	6-5/8FH	8 1/4	4 3/4
6 5/8	27.70	IEU	SS105 / HL110SS / HL120S / HL125S	HLIDS®6-5/8FH	8	5

Note: Abbreviated steel grade

SS75 - HLDT-SS®75; SS95 - HLDT-SS®95; SS105 - HLDT-SS®105; HL110SS - HLDT-SS®110; HL120S - HLDT-S®120;

HL125S - HLDT-S®125.

Table B.3 Commonly-used Heavy Weight Drill Pipes Data

Size	Pipe Body OD	Pipe Body ID	Central Upset OD	Elevator Upset OD	RSC Type	RSC Bevel Dia.	Tool Joint OD	Tool Joint ID	Drift Size
in	in	in	in	in		in	in	in	in
3 1/2	3 1/2	2 1/4	4.000	3.875	NC38	4.578	4 3/4	2 1/4	2.000
3 1/2	3 1/2	2 1/16	4.000	3.875	NC38	4.578	5	2 1/16	1.813
3 1/2	3 1/2	2	4.000	3.638	HLIDS®31	3.953	4 1/8	2	1.750
3 1/2	3 1/2	2 1/16	4.000	3.638	HLST®31	3.906	4 1/8	2 1/16	1.813
3 1/2	3 1/2	2 1/4	4.000	3.875	HLIDS®38	4.578	4 3/4	2 1/4	2.000
3 1/2	3 1/2	2 1/4	4.000	3.875	HLMT®38	4.578	4 3/4	2 1/4	2.000
4	4	2 9/16	4.500	4.188	NC40	5.016	5 1/4	2 9/16	2.313
4	4	2 9/16	4.500	4.188	HLIDS®40	5.016	5 1/4	2 9/16	2.313
4	4	2 9/16	4.500	4.188	HLMT®40	4.875	5 1/4	2 9/16	2.313
4	4	2 9/16	4.500	4.188	HLST®39	4.772	4 7/8	2 9/16	2.313
4	4	2 9/16	4.500	4.188	HLIST®39	4.786	4 7/8	2 9/16	2.313
4 1/2	4 1/2	2 11/16	5.000	4.688	NC46	5.719	6 1/4	2 11/16	2.438
4 1/2	4 1/2	2 11/16	5.000	4.688	HLIDS®40	5.016	5 1/4	2 11/16	2.438
4 1/2	4 1/2	2 11/16	5.000	4.688	HLST®40	5.063	5 1/4	2 11/16	2.438
5	5	3	5.500	5.125	NC50	6.063	6 5/8	3	2.750
5	5	3	5.500	5.125	HLIDS®50	6.063	6 5/8	3	2.750
5 1/2	5 1/2	4	6.000	5.688	5-1/2FH	6.719	7	4	3.750
5 1/2	5 1/2	3 1/4	6.000	5.688	5-1/2FH	6.719	7	3 1/4	3.000
5 1/2	5 1/2	3 1/4	6.000	5.688	HLIST®50	6.318	6 1/2	3 1/4	3.000
5 1/2	5 1/2	3 1/4	6.000	5.688	HLIDS®5-1/2FH	6.719	7	3 1/4	3.000
5 1/2	5 1/2	4	6.000	5.688	HLST®54	6.472	6 3/4	4	3.750
5 1/2	5 1/2	4	6.000	5.688	HLIST®54	6.469	6 5/8	4	3.750
5 7/8	5 7/8	4	6.375	6.000	HLIDS®5-1/2FH	6.719	7 1/4	4	3.750
5 7/8	5 7/8	4 1/8	6.375	6.000	HLST®57	6.764	7	4 1/8	3.875
5 7/8	5 7/8	4 1/4	6.375	6.000	HLIST®57	6.721	7	4 1/4	4.000
6 5/8	6 5/8	4 1/2	7.125	6.938	6-5/8FH	7.703	8 1/4	4 1/2	4.250
6 5/8	6 5/8	5	7.125	6.938	6-5/8FH	7.703	8	5	4.750
6 5/8	6 5/8	5	7.125	6.937	HLIDS®6-5/8	7.703	8	5	4.750

Table B.4 Commonly-used Drill Collars Data

Size	OD	Bore	RSC Type	Length	RSC Bevel Dia.	Reference Bending Strength Ratio	Drift
	D	d		L	Df	BSR	
in	in	in		FT	in		in
3 1/8	3 1/8	1 1/4	NC23	30	3.000	2.57	1.375
3 1/2	3 1/2	1 1/2	NC26	30	3.266	2.42	1.625
4 1/8	4 1/8	2	NC31	30 or 31	3.953	2.43	2.125
4 3/4	4 3/4	2	NC35	30 or 31	4.516	2.58	2.125
5	5	2 1/4	NC38	30 or 31	4.766	2.38	2.375
6	6	2 1/4	NC44	30 or 31	5.688	2.49	2.375
6	6	2 13/16	NC44	30 or 31	5.688	2.84	2.938
6 1/4	6 1/4	2 1/4	NC44	30 or 31	5.875	2.91	2.375
6 1/4	6 1/4	2 13/16	NC46	30 or 31	5.906	2.63	2.938
6 1/2	6 1/2	2 1/4	NC46	30 or 31	6.094	2.76	2.375
6 1/2	6 1/2	2 13/16	NC46	30 or 31	6.094	3.05	2.938
6 3/4	6 3/4	2 1/4	NC46	30 or 31	6.281	3.18	2.375
7	7	2 1/4	NC50	30 or 31	6.484	2.54	2.375
7	7	2 13/16	NC50	30 or 31	6.484	2.73	2.938
7 1/4	7 1/4	2 13/16	NC50	30 or 31	6.672	3.12	2.938
7 3/4	7 3/4	2 13/16	NC56	30 or 31	7.297	2.70	2.938
8	8	2 13/16	NC56	30 or 31	7.484	3.02	2.938
8 1/4	8 1/4	2 13/16	6-5/8REG	30 or 31	7.703	2.93	2.938
9	9	2 13/16	NC61	30 or 31	8.375	3.17	2.938
9 1/2	9 1/2	3	7-5/8REG	30 or 31	8.813	2.81	3.125
9 3/4	9 3/4	3	NC70	30 or 31	9.156	2.57	3.125
10	10	3	NC70	30 or 31	9.344	2.81	3.125
11	11	3	8-5/8REG	30 or 31	10.500	2.84	3.125

Table B.5 HLIDS® Connection Mechanical Characteristics

RSC Type	Tool Joint OD (in)	Tool Joint ID (in)	Torsional Strength (ft-lb)	Tensile Strength (lb)	Recommended Makeup Torque (ft-lb)
HLIDS®23	3.000	1.375	6500	284200	3900
HLIDS®26	3.375	1.750	8900	313700	5300
HLIDS®31	4.375	1.625	24000	623800	14400
	4.125	2.125	15300	447100	9200
	4.125	2.000	17700	495700	10600
HLIDS®38	5.000	2.563	26600	649200	16000
	5.000	2.438	30000	708100	18000
	5.000	2.125	37500	842400	22500
	4.750	2.688	22800	587300	13700
	4.750	2.563	25400	649200	15300
HLIDS®40	5.500	2.000	51800	1080100	31100
	5.250	2.813	29500	711600	17700
	5.250	2.688	33400	776400	20100
	5.250	2.563	37200	838300	22300
	5.250	2.438	40300	897200	24200
HLIDS®46	6.000	3.250	44000	901200	26400
	6.000	3.000	54100	1048400	32500
	6.000	2.750	63200	1183900	37900
HLIDS®50	6.625	3.750	48800	939100	29300
	6.625	3.500	61600	1109900	37000
	6.625	3.250	73400	1269000	44000
	6.625	3.000	84100	1416200	50500
	6.625	2.750	93900	1551700	56300
	6.500	3.750	48600	939100	29200
HLIDS®5-1/2FH	7.500	3.250	117000	1778300	70200
	7.500	3.000	128700	1925500	77200
	7.250	3.750	89800	1448400	53900
	7.250	3.625	96900	1535300	58100
	7.250	3.500	103600	1619200	62200
	7.000	4.000	74400	1265800	44700
	7.000	3.875	82000	1358600	49200
HLIDS®6-5/8FH	8.250	4.750	119700	1678100	71800
	8.250	4.625	130200	1788600	78100
	8.000	5.000	97200	1448400	58300
	8.000	4.875	108300	1564800	65000

Note: All data is calculated based on SMYS 120ksi, and Makeup Torques are based on a friction factor of 1.0.

Table B. 6 HLMT® Connection Mechanical Characteristics

RSC Type	Tool Joint OD (in)	Tool Joint ID (in)	Torsional Strength (ft-lb)	Tensile Strength (lb)	Recommended Makeup Torque (ft-lb)
HLMT®2-3/8PAC	2.875	1.375	7000	238500	4200
HLMT®2-7/8PAC	3.125	1.500	8500	273000	5100
HLMT®38	5.000	2.563	29600	649200	17700
	5.000	2.438	33000	708100	19800
	5.000	2.250	37700	790900	22600
	4.875	2.438	32800	708100	19700
	4.750	2.688	25700	587300	15400
	4.750	2.563	28400	649200	17000
HLMT®40	5.500	2.438	43800	897200	26300
	5.250	2.688	36100	776400	21700
	5.250	2.563	39900	838300	23900
	5.250	2.438	43100	897200	25800
HLMT®46	6.000	3.250	47200	901200	28300
	6.000	3.000	57300	1048400	34400
HLMT®50	6.625	3.500	66200	1109900	39700
	6.625	3.250	78000	1269000	46800
	6.625	3.000	88800	1416200	53300
	6.500	3.500	65900	1109900	39600
HLMT®5-1/2FH	7.000	4.000	77200	1265800	46300
HLMT®5-1/2FH	7.000	3.875	84800	1358600	50900

Note: All data is calculated based on SMYS 120ksi, and Makeup Torques are based on a friction factor of 1.0.

Table B. 7 HLST® Connection Mechanical Characteristics

RSC Type	Tool Joint OD (in)	Tool Joint ID (in)	Torsional Strength (ft-lb)	Tensile Strength (lb)	Recommended Makeup Torque (ft-lb)
HLST®26	3.375	1.750	11100	296500	6600
HLST®31	4.125	2.125	19000	433900	11400
	4.125	2.000	21500	482500	12900
	4.000	2.250	16300	382300	9800
HLST®36	4.750	2.563	24400	502700	14700
	4.750	2.438	27800	561600	16700
	4.750	2.250	32400	644500	19500
	4.750	2.125	35300	696000	21200
HLST®39	5.000	2.563	38900	723300	23300
	5.000	2.438	41900	782200	25100
	4.875	2.813	31100	596700	18600
	4.875	2.688	34600	661500	20800
	4.875	2.563	36300	723300	21800
HLST®40	5.375	2.563	49800	869300	29900
	5.250	2.688	45800	807500	27500
	5.250	2.563	49000	869300	29400
HLST®46	6.250	3.000	70100	1090700	42000
	6.250	2.750	79600	1226200	47700
	6.000	3.500	47800	784400	28700
	6.000	3.250	59200	943400	35500
	6.000	3.000	69600	1090700	41800
HLST®52	6.625	4.000	62300	917500	37400
	6.625	3.750	76800	1100100	46100
	6.625	3.500	90300	1270900	54200
	6.500	4.125	54500	821700	32700
	6.500	4.000	62100	917500	37300
HLST®54	6.875	3.750	98800	1333800	59300
	6.750	4.125	75700	1055400	45400
	6.750	4.000	83600	1151200	50100
	6.625	4.250	67300	956800	40400
HLST®57	7.125	4.000	109800	1437800	65900
	7.000	4.250	92900	1243400	55700
	7.000	4.000	103000	1437800	61800

Note: All data is calculated based on SMYS 120ksi, and Makeup Torques are based on a friction factor of 1.0.

Table B. 8 HLIST® Connection Mechanical Characteristics

RSC Type	Tool Joint OD (in)	Tool Joint ID (in)	Torsional Strength (ft-lb)	Tensile Strength (lb)	Recommended Makeup Torque (ft-lb)
HLIST®38	4.875	2.438	34900	658500	20900
	4.750	2.688	27700	537800	16600
	4.750	2.563	31300	599600	18800
	4.750	2.438	34800	658500	20900
HLIST®39	5.000	2.563	40800	729700	24500
	4.875	2.688	35900	667800	21600
HLIST®46	4.875	2.563	37600	729700	22600
	6.250	3.250	70200	1069300	42100
	6.000	3.500	58100	910300	34900
HLIST®50	6.000	3.250	65700	1069300	39400
	6.625	3.500	90900	1256300	54600
	6.625	3.375	97200	1337300	58300
	6.500	3.750	77300	1085500	46400
HLIST®54	6.500	3.625	84100	1172400	50500
	6.750	4.000	86600	1155100	52000
	6.750	3.875	94300	1247900	56600
	6.625	4.250	70200	960700	42100
HLIST®57	6.625	4.000	84300	1155100	50600
	7.000	4.250	94600	1208700	56800
	7.000	4.000	107700	1403100	64600

Note: All data is calculated based on SMYS 120ksi, and Makeup Torques are based on a friction factor of 1.0.

Appendix C

Table C.1 Hilong Drilling Tools Request for Quotation Template

Company Name: _____ Inquiry Date: _____ Inquiry Deadline: _____
 Attn: _____ Email: _____ Delivery Term: _____
 Phone #: _____ Address: _____ Product Used Area: _____

	Drill Pipe		Heavy Weight Drill Pipe		Drill Collar	Subs	
	Nomal Weight	Thick-Walled	Welded Type	Integral Type	<input type="checkbox"/> Normal <input type="checkbox"/> Non-magnetic	<input type="checkbox"/> A <input type="checkbox"/> B <input type="checkbox"/> C <input type="checkbox"/> D	
Product Specification							
Quantity							
Pipe Designation	Size (OD)	mm in	mm in	mm in	mm in	mm in	
	Nominal Wall Thickness	mm in					
	Wall Thickness		mm in				
	Bore (ID)			mm in	mm in	mm in	
	Upsetting Type	<input type="checkbox"/> IU <input type="checkbox"/> EU <input type="checkbox"/> IEU	<input type="checkbox"/> IU <input type="checkbox"/> EU <input type="checkbox"/> IEU				
	Grade	<input type="checkbox"/> E75 <input type="checkbox"/> X95 <input type="checkbox"/> G105 <input type="checkbox"/> S135 <input type="checkbox"/> HLDT-SH*Z140 <input type="checkbox"/> HLDT-SH*V150 <input type="checkbox"/> HLDT-SH*U165 <input type="checkbox"/> HLDT-SS*75 <input type="checkbox"/> HLDT-SS*95 <input type="checkbox"/> HLDT-SS*105 <input type="checkbox"/> HLDT-SS*110 <input type="checkbox"/> HLDT-S*120 <input type="checkbox"/> HLDT-S*125 or _____	<input type="checkbox"/> G105 <input type="checkbox"/> S135 <input type="checkbox"/> HLDT-SH*Z140 <input type="checkbox"/> HLDT-SH*V150 <input type="checkbox"/> HLDT-SH*U165 or _____	<input type="checkbox"/> 55KSI <input type="checkbox"/> 75KSI <input type="checkbox"/> 90KSI <input type="checkbox"/> 95KSI <input type="checkbox"/> 110KSI <input type="checkbox"/> HLHW-SS*75 <input type="checkbox"/> HLHW-SS*90 or _____	<input type="checkbox"/> 55KSI <input type="checkbox"/> 75KSI <input type="checkbox"/> 90KSI <input type="checkbox"/> 95KSI <input type="checkbox"/> 110KSI <input type="checkbox"/> HLHW-SS*75 <input type="checkbox"/> HLHW-SS*90 or _____		
Range/Length	<input type="checkbox"/> R1 <input type="checkbox"/> R2 <input type="checkbox"/> R3 or _____	<input type="checkbox"/> R1 <input type="checkbox"/> R2 <input type="checkbox"/> R3 or _____	<input type="checkbox"/> R1 <input type="checkbox"/> R2 <input type="checkbox"/> R3 or _____	<input type="checkbox"/> R1 <input type="checkbox"/> R2 <input type="checkbox"/> R3 or _____	<input type="checkbox"/> R1 <input type="checkbox"/> R2 <input type="checkbox"/> R3 or _____		
	Common: Shoulder-Shoulder or _____	Common: Shoulder-Shoulder or _____	Common: Total Length or _____	Common: Total Length or _____	Common: Total Length or _____	Common: Total Length or _____	
Spiral Groove			<input type="checkbox"/> Yes <input type="checkbox"/> No	<input type="checkbox"/> Yes <input type="checkbox"/> No	<input type="checkbox"/> Yes <input type="checkbox"/> No		
Tool Joint	Tool Joint/Connection Type						
	Box OD	mm in	mm in	mm in	mm in	mm in	
	Pin ID	mm in	mm in	mm in	mm in	mm in	
	Box Tong Space	mm in	mm in	mm in	mm in	mm in	
	Pin Tong Space	mm in	mm in	mm in (Including Pin Thread Length <input type="checkbox"/> Yes <input type="checkbox"/> No)	mm in (Including Pin Thread Length <input type="checkbox"/> Yes <input type="checkbox"/> No)	mm in	mm in
Options	Option 1: Break in						
	Option 2: Thread Cold Rolling						
	Option 3: Stress Relief Features						
	Option 4: Slip Recess						
	Option 5: Elevator Recess						
	Option 6: Internal Coating						
	Option 7: Hardbanding	Type					
		Required on	<input type="checkbox"/> Box <input type="checkbox"/> Pin	<input type="checkbox"/> Box <input type="checkbox"/> Pin	<input type="checkbox"/> Box <input type="checkbox"/> Pin <input type="checkbox"/> Center Pad	<input type="checkbox"/> Box <input type="checkbox"/> Pin <input type="checkbox"/> Center Pad	<input type="checkbox"/> Box <input type="checkbox"/> Pin <input type="checkbox"/> Center Pad
		Length(in)/ Location on Box	mm in	mm in	mm in	mm in	mm in
		Length(in)/ Location on Pin	mm in	mm in	mm in	mm in	mm in
Length(in)/ Location on Center Pad							
Length(in)/ Location near slip or elevator recess							
Remarks							

Grey cells indicate feature does not apply.

Contact Us

Hilong Drilling Tools Sales and Service Network



China

Domestic Sales Center

Add: No.1825, Luodong Rd., Baoshan Industrial Zone, Shanghai

Tel: +86 21 33851809

E-mail: sales@hilonggroup.com

International Sales Center

Add: No.1825, Luodong Rd., Baoshan Industrial Zone, Shanghai

Tel: +86 21 33851202

E-mail: sales@hilonggroup.com

UAE

Hilong Petroleum Pipe Company LLC

Add: 24FR, Plot 6, ICAD 1, Musaffah, Abu Dhabi, United Arab Emirates.

Tel: +971 2 5512513

Website: www.hilonguae.com

E-mail: sales@hilonguae.com

America

Hilong USA LLC

Add: 10333 Richmond Ave, Suite: 1025, Houston, TX, USA, 77042

Tel: +1 (281) 692-4945

E-mail: zhouxiaogang@hilonggroup.com

Canada

Hilong Petropipe Co. Ltd

Add: 1103 17th Ave Nisku, Alberta, Canada, Post Code: T9E0N1

Tel: 7809790731

E-mail: office@hilongcanada.com

Hilong Drilling Tools Manufacturing base

China

Shanghai Hilong Drill Pipe Co., Ltd.

(Drill pipe, Heavy weight drill pipe, Drill collar production)

Add: No.1825, Luodong Rd., Baoshan Industrial Zone, Shanghai

Tel: +86 21-33851886

Hilong Drill Pipe (Wuxi) Co., Ltd. (Drill pipe tool joint production)

Add: No.217 Xitai Road, Mei Village, Xinwu District, Wuxi City, Jiangsu Province

Tel: +86 0510-85366075



Drilling Tools



www.hilonggroup.com

